



OUTDOOR BOARDS



BASE TIER BOARDS



CONTROL PANEL BASE TIER HP

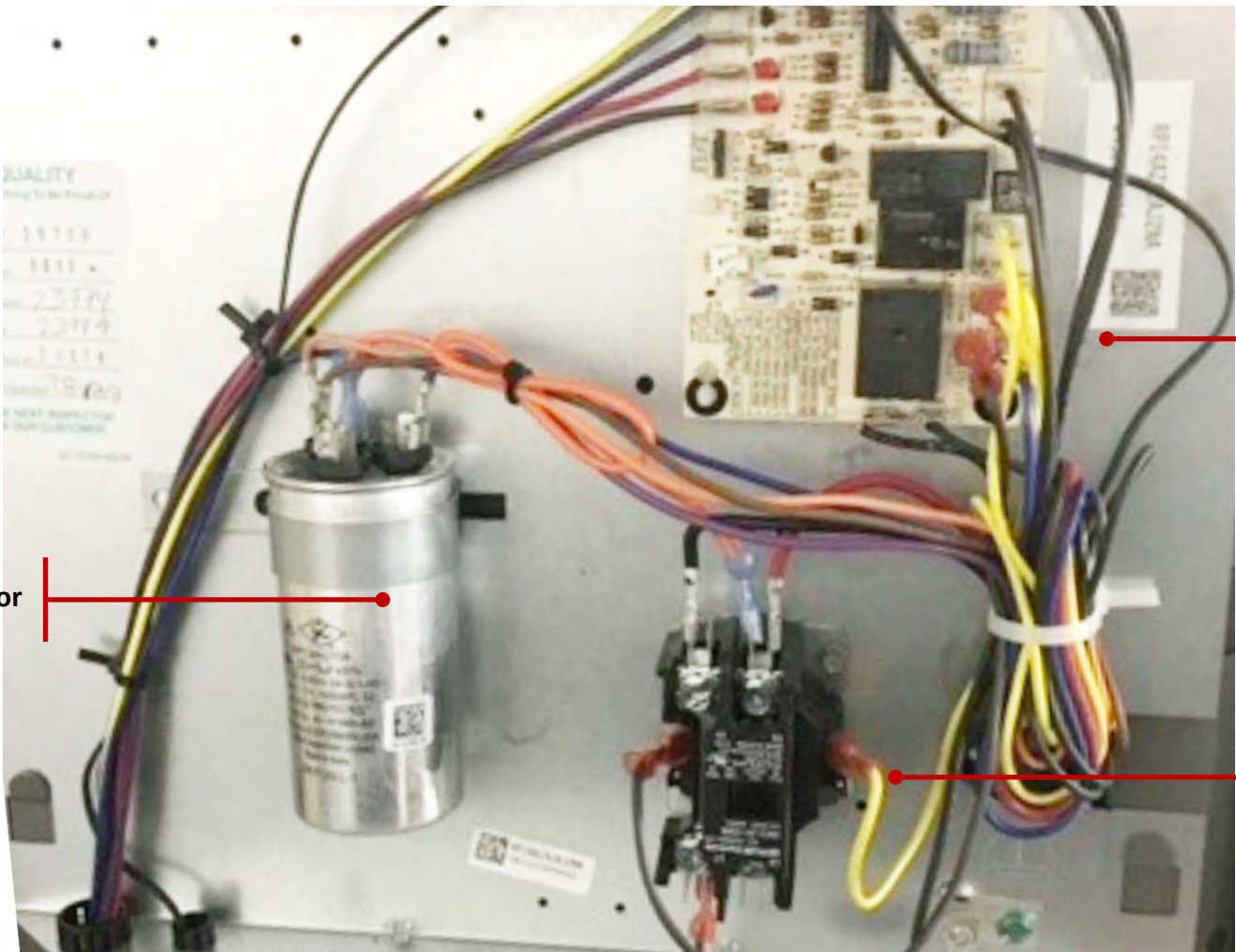

Dual Capacitor

Defrost Board

Contactor



DEFROST CONTROL BOARD - BASE-TIER HP

LED 1	LED 2	Control Board Status
OFF	OFF	No Power
ON	ON	Coil Sensor Failure
OFF	ON	Ambient Sensor Failure
FLASH	FLASH	Normal
OFF	FLASH	Low Pressure Lockout (short test pins to reset)
FLASH	OFF	High Pressure Lockout (short test pins to reset)
ON	FLASH	Low Pressure Control Open
FLASH	ON	High Pressure Control Open
Alternate Flashing		5 Minute Time Delay

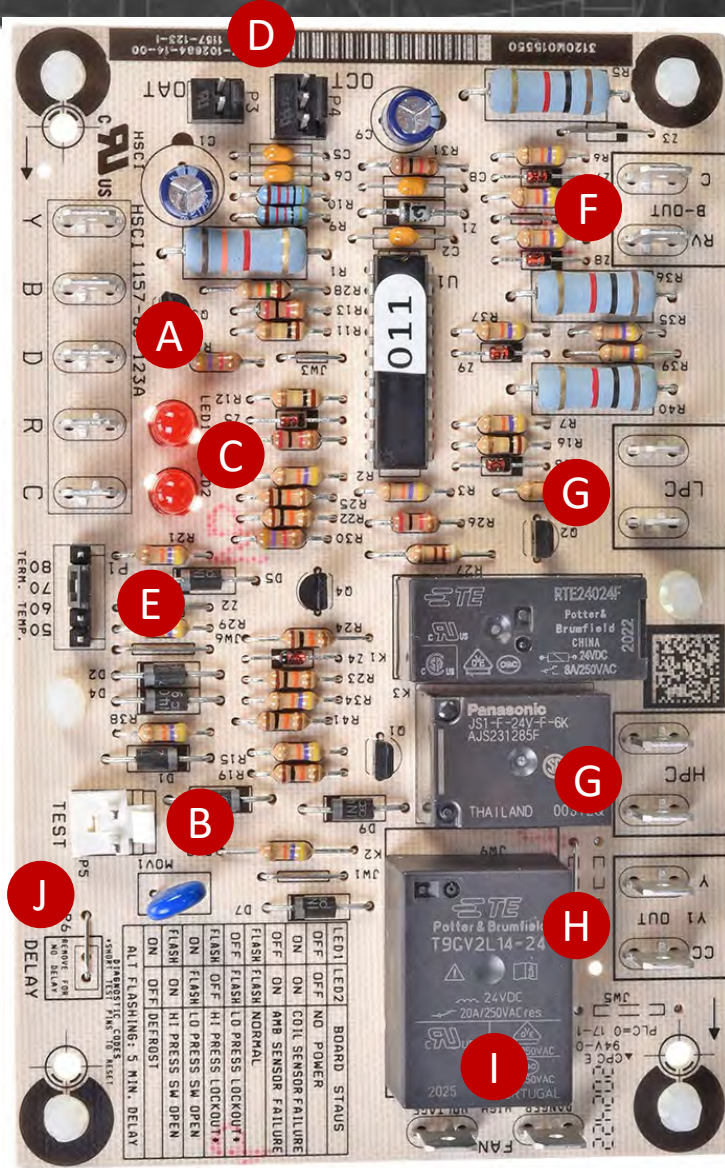

- A** T-stat connection
- B** Test Pins
- C** Diagnostic LED's
- D** T-stat connection
- E** Defrost Termination
- F** C & RRV Terminals
- G** LPC & HPC Terminals (standard)
- H** Y & CC Terminals
- I** OD Fan Terminals
- J** 0 Second Delay Jumper



BASE-TIER DEFROST SEQUENCE

Demand Defrost

Defrost initiated when three required conditions are satisfied:

1. Outdoor coil temperature below 35°F [1.7°C] measured at coil sensor
2. Compressor has operated for at least 34 minutes with outdoor coil temperature below 35°F [1.7°C]
3. Measured difference between the ambient temperature and outdoor coil temperature is greater than the calculated difference determined by the microprocessor

Defrost Cycle

1. Control will enter 30 second delay with compressor off (unless jumper is cut)
2. Outdoor fan & reversing valve are de-energized
3. 24 volts is energized to the D wire initiates auxiliary heat
4. Compressor is energized & system is in cooling mode

Defrost Termination

Once a defrost is initiated, the defrost will continue until 14 minutes has elapsed or the coil temperature has reached the selected termination temperature.

- The factory setting is 70°F [21.1°C] but can be changed to 50°F [10°C], 60°F [15.6°C] or 80°F [26.7°C] by relocating the jumper on the control board.



BASE TIER HP WIRING DIAGRAM

Y2 from the thermostat must wire to the blue wire coming from the compressor solenoid.

Base Tier HP has a 2-stage compressor

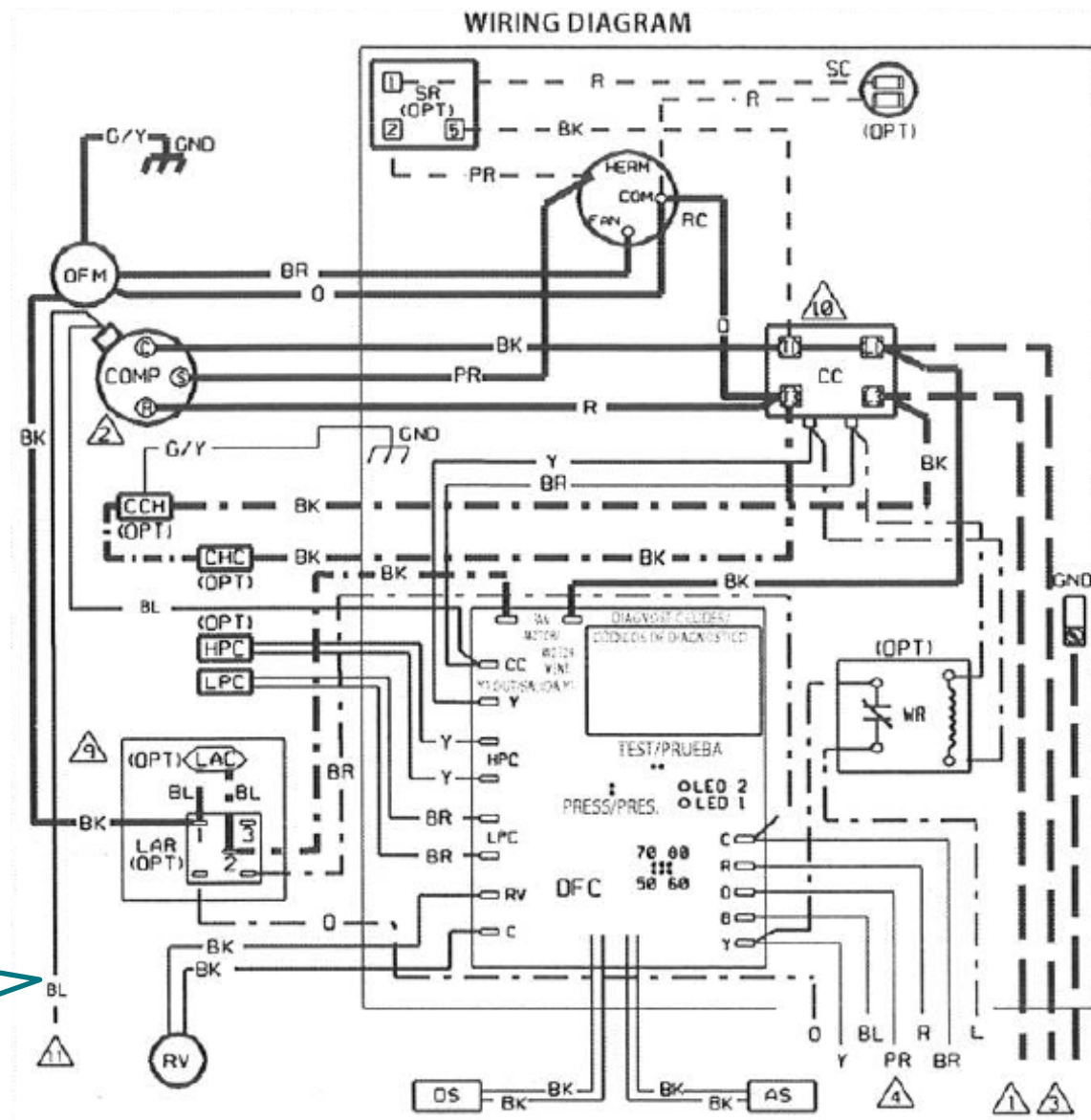



BASE TIER HP WIRING DIAGRAM

Example of 24 volt 2nd stage solenoid wiring

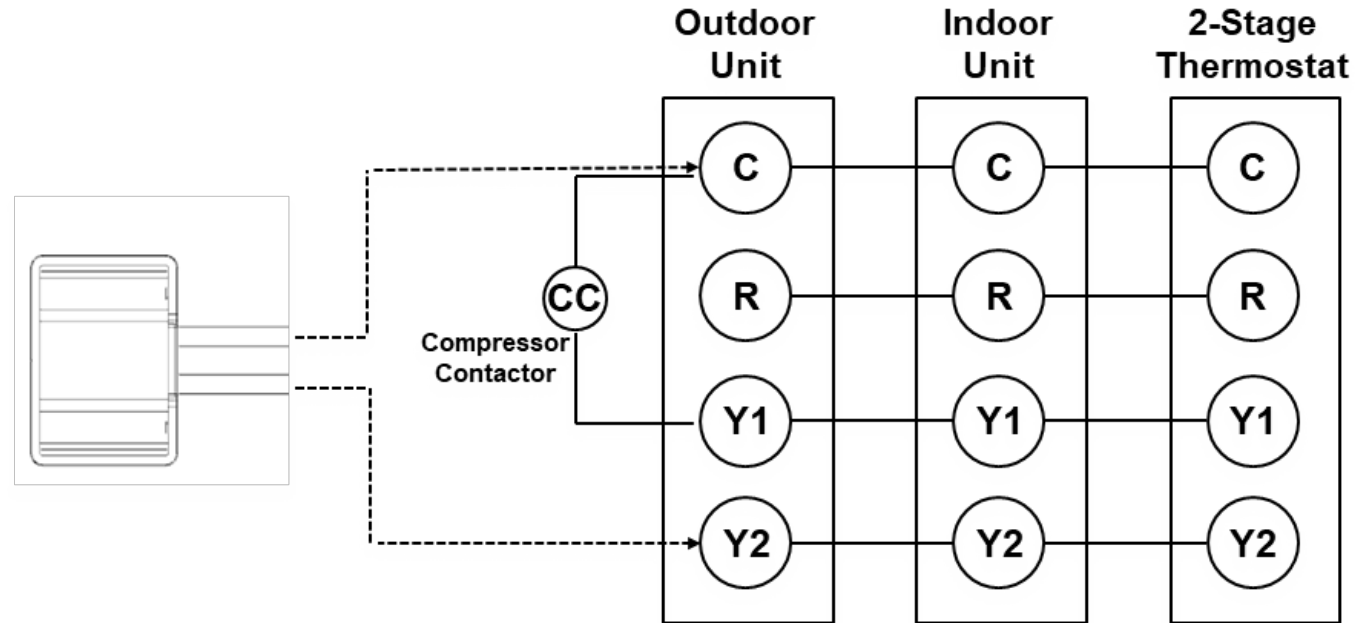

Full Load – 100% Capacity of displacement, solenoid power on.

Part Load – approximately 65% Capacity of full load capacity, solenoid power off.



MID-TIER BOARDS



RA15 / UA16 / UP16

Variable Speed Twin Rotary Compressor & Inverter Drive:

- Features variable speed operation from 45% to 70% capacity, or 100% capacity via line voltage, with the EcoNet[®] Smart Thermostat
- 3-speed operation when installed with a 24V two-stage thermostat
- Provides precise temperature control, advanced humidity control and greater efficiency





UNIVERSAL OUTDOOR CONTROL (UODC) – MID AND HIGH TIER

- Name change from VSODU
- There is no memory card on the UODC
- No 7-segment display
- All diagnostic codes are read through EcoNet or Contractor App
- Bluetooth Antenna
- If a UODC is replaced, it must be set up on-site via Bluetooth connection to the app
- Expanded information is in the Contractor App training
- Same sensors as previous models

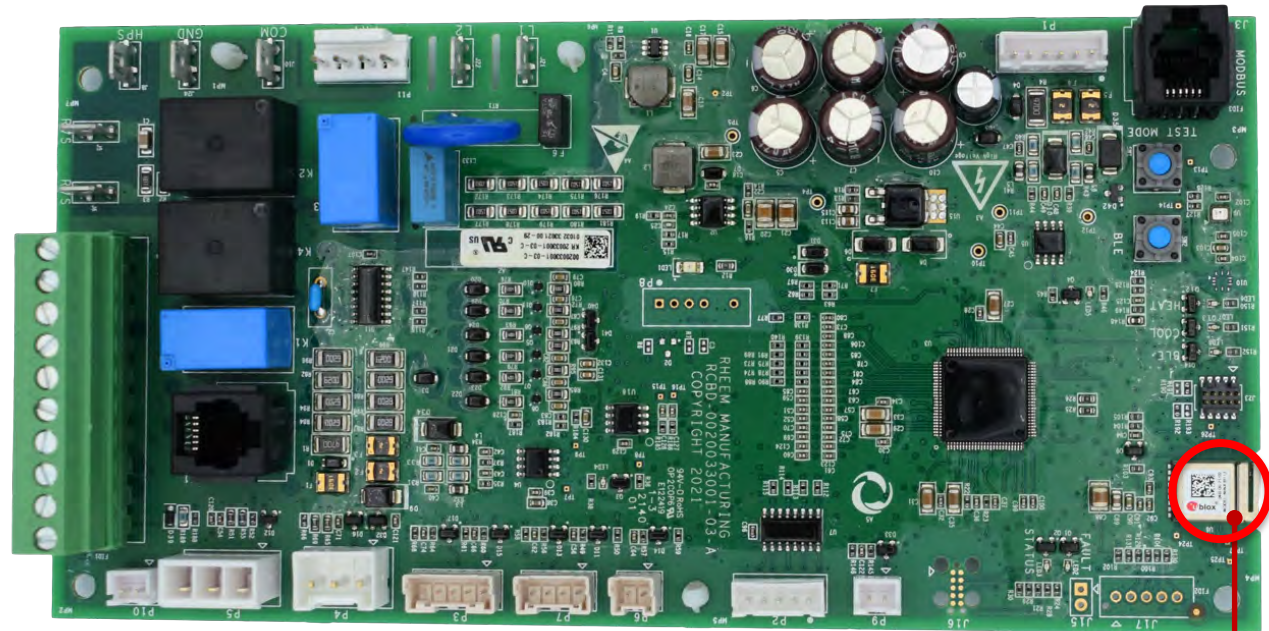

**Bluetooth®
Transmitter / Receiver**



MID TIER CONTROL PANEL

Modbus to P1
On UODC

Inverter Drive

Ferrite Ring

Terminal Block

Modbus to J130
on Drive

Universal Outdoor
Control (UODC)

Capacitor

Contactor

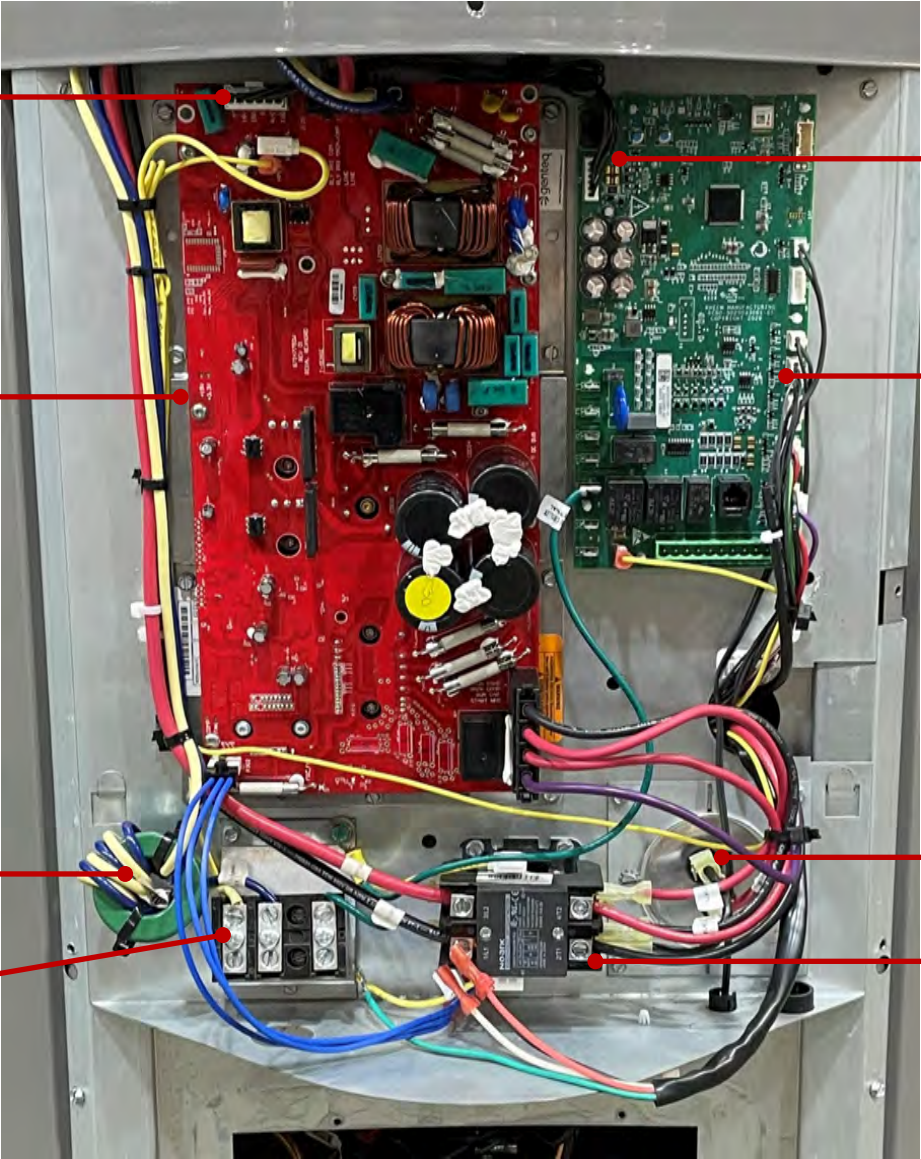



UODC COMPONENT CONNECTIONS

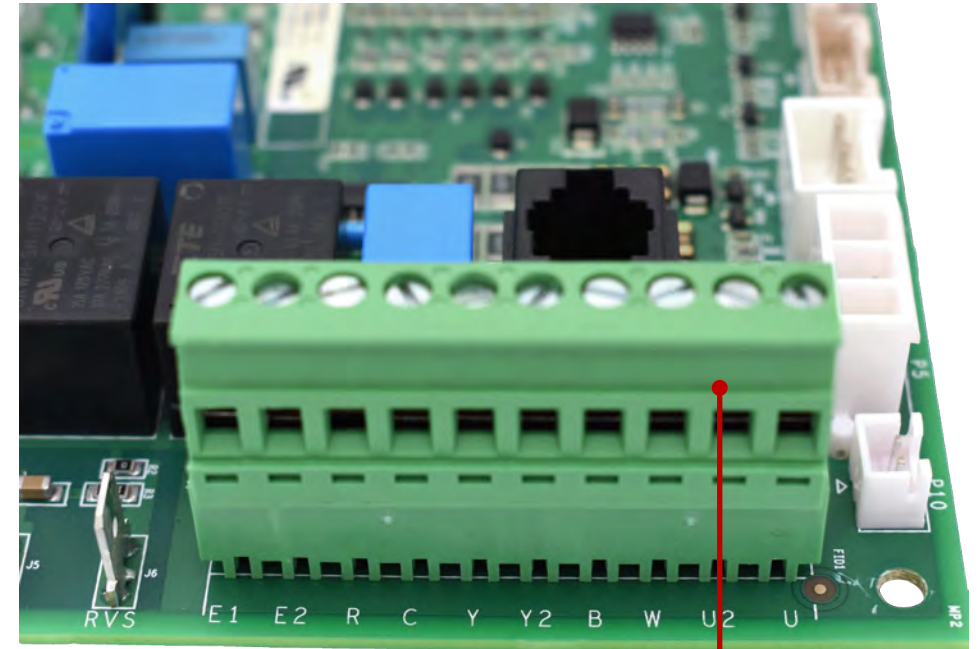
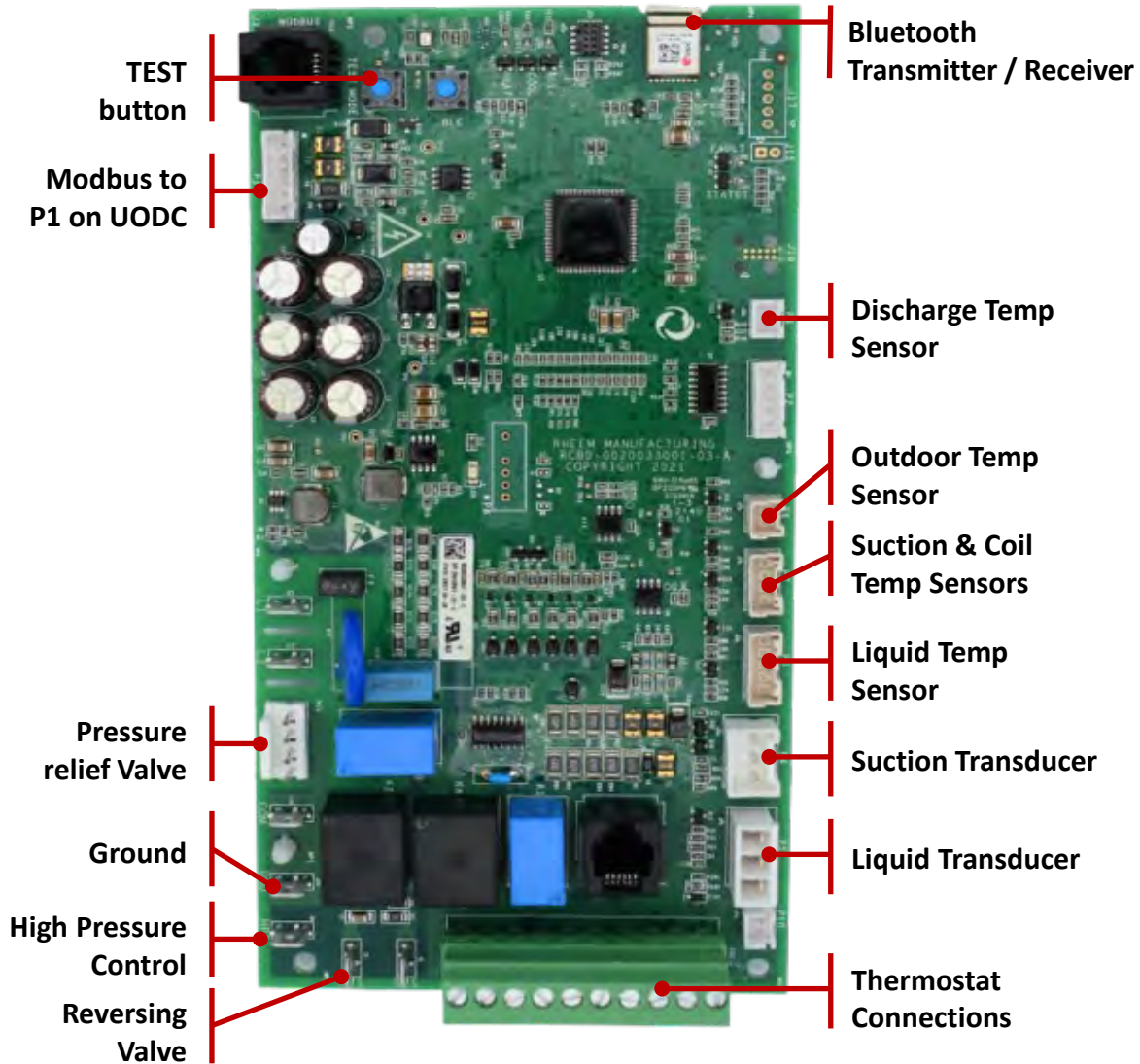



UODC LEDS

- **BLE - Green LED**
 - When blinking, Bluetooth is available to connect
 - When solid, Bluetooth is connected
- **Cool – Green LED**
 - Slow blink – Call present, but unit is in delay or lockout
 - Fast blink – one blink for every 10% of capacity being called for
 - e.g. 7 blinks for ~70%
 - 1 second rate of blink
 - 2 second rate of rest, then repeats
- **Heat – Amber LED**
 - Blinks same as Cool
 - Defrost – Heat and Cool LEDs alternate every one second

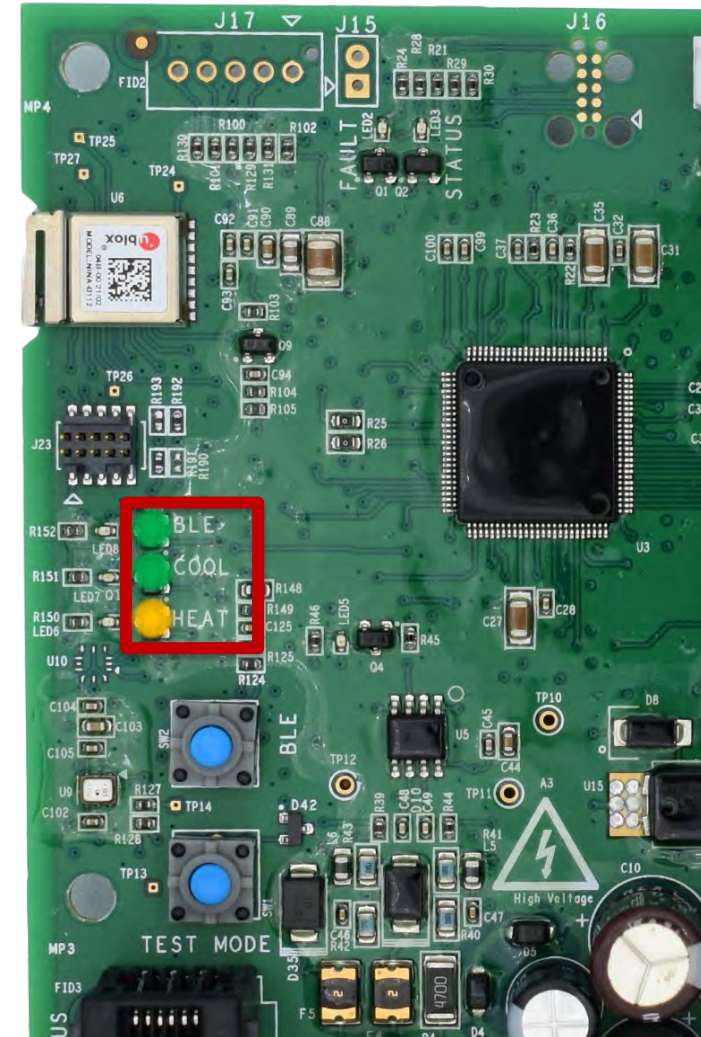



MID-TIER HP – WIRING DIAGRAM

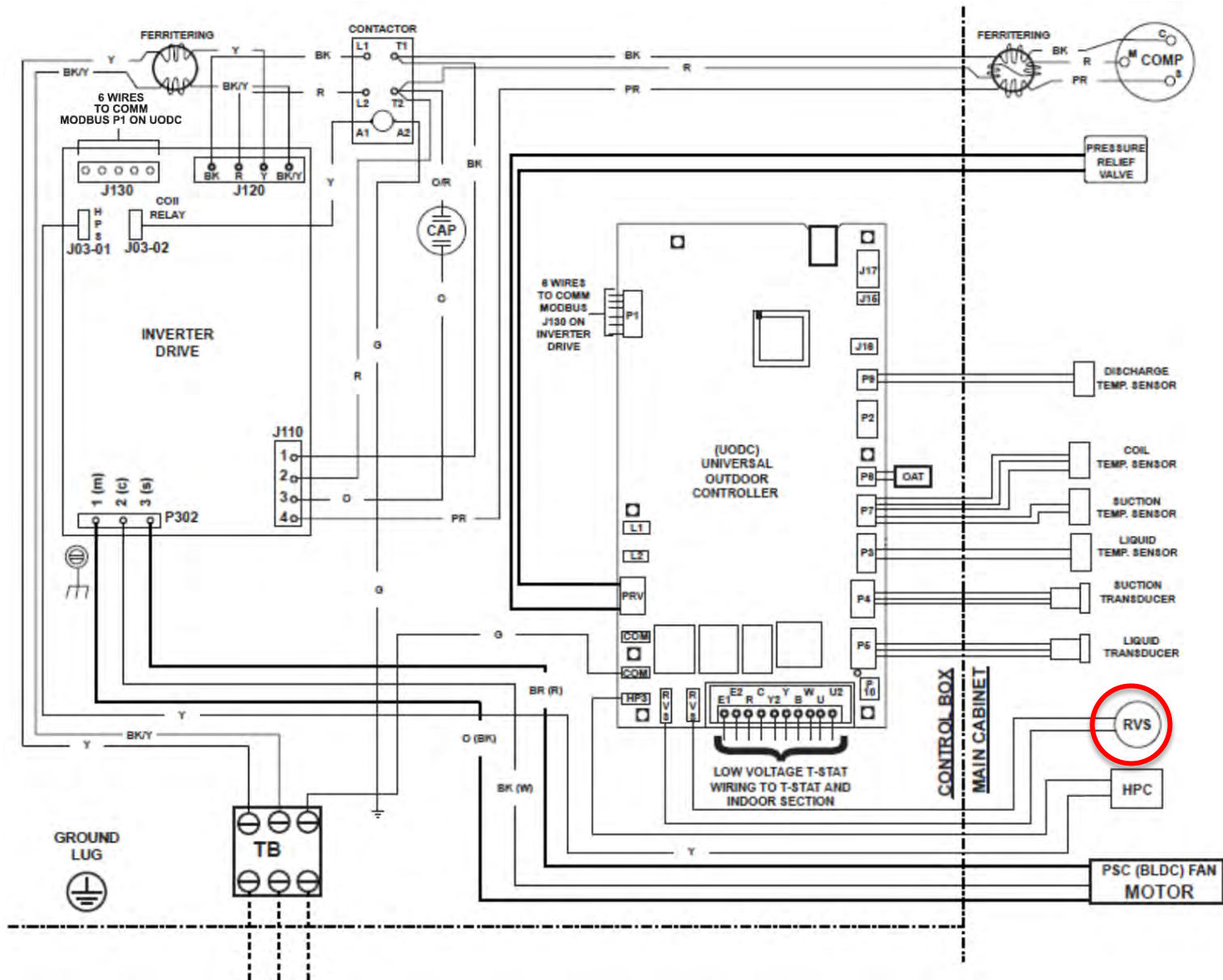

WIRING INFORMATION

- LINE VOLTAGE
- FACTORY STANDARD
- FACTORY OPTION
- FIELD INSTALLED
- LOW VOLTAGE
- FACTORY STANDARD
- FIELD INSTALLED
- REPLACEMENT WIRE
- MUST BE THE SAME SIZE AND TYPE OF INSULATION AS ORIGINAL (105C. MIN.)

WARNING
 -CABINET MUST BE PERMANENTLY GROUNDED AND CONFORM TO I.E.C., N.E.C., C.E.C., NATIONAL WIRING REGULATIONS, AND LOCAL CODES AS APPLICABLE.

WIRE COLOR CODE

- BK.....BLACK G.....GREEN PR.....PURPLE
- BR.....BROWN G Y.....GRAY R.....RED
- BL.....BLUE O.....ORANGE W.....WHITE
- Y.....YELLOW

COMPONENT CODES

- CAP CAPACITOR
- COM COMMON
- COMP COMPRESSOR
- DLT DISCHARGE LINE THERMISTOR
- GND GROUND
- HPC HIGH PRESSURE CONTROL
- HPS HIGH PRESSURE SWITCH
- OAT OUTDOOR AMBIENT TEMPERATURE
- OFM OUTDOOR FAN MOTOR
- PRV PRESSURE RELIEF VALVE
- RVS REVERSING VALVE SOLENOID
- TB TERMINAL BLOCK



THERMOSTAT WIRING - ECONET

- Requires continuous 18 AWG thermostat wire.
 - Do not use phone cord to connect indoor and outdoor units. This will damage the controls.
- The EcoNet™ control system requires four control wires for unit operation:
 - R 24 VAC
 - C 24 VAC common
 - E1 Communications
 - E2 Communications
- The EcoNet™ enabled air handler or furnace is equipped with a 24-volt, 40 or 50 VA transformer for proper system operation. See the wiring diagram below for low voltage wiring connections.
- U, U2 terminals can be used for utility load shedding
 - Must be programmed at EcoNet Smart Thermostat or app

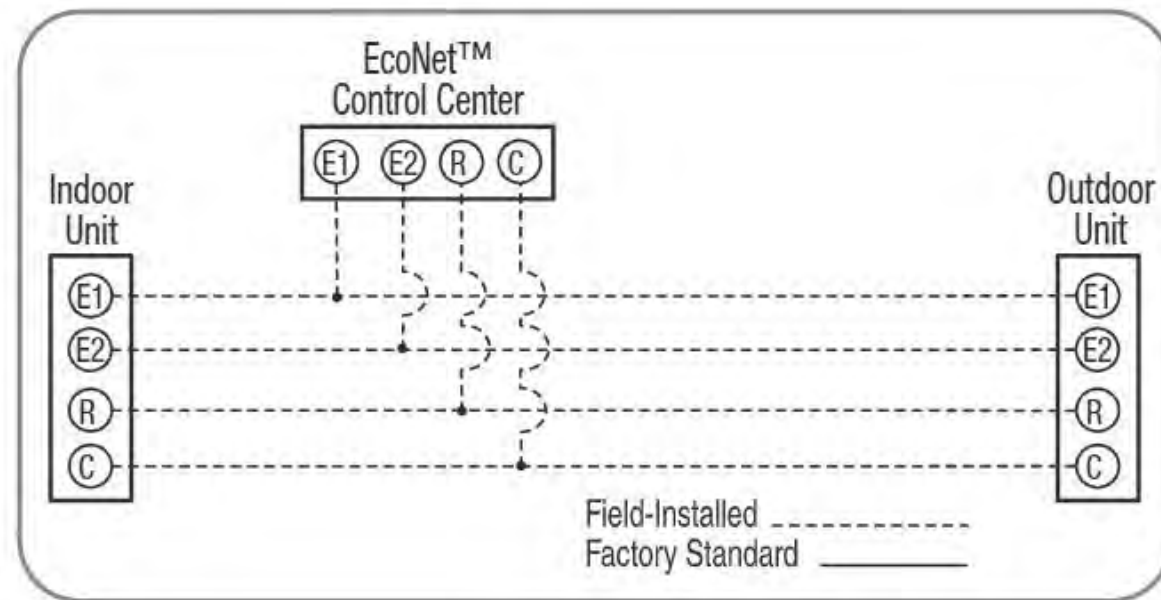



THERMOSTAT WIRING - LEGACY

Thermostat control wiring requires a minimum of six (6) wires for proper heat pump operation and five (5) wires for proper AC operation:

- R – 24 VAC (AC/HP)
- C – 24 VAC common (AC/HP)
- Y1 – 1st stage compressor (AC/HP)
- Y2 – 2nd stage compressor (AC/HP)
- G – Indoor fan control
- B – Heat pump operation (HP)
- W – Supplemental heat during defrost cycle (AC/HP)

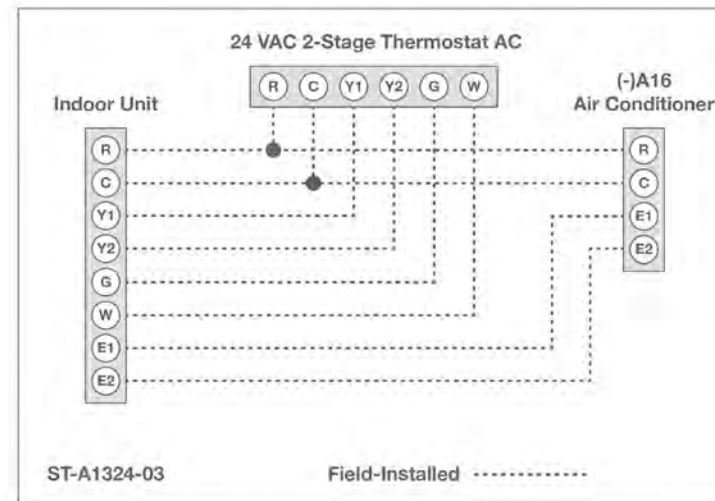
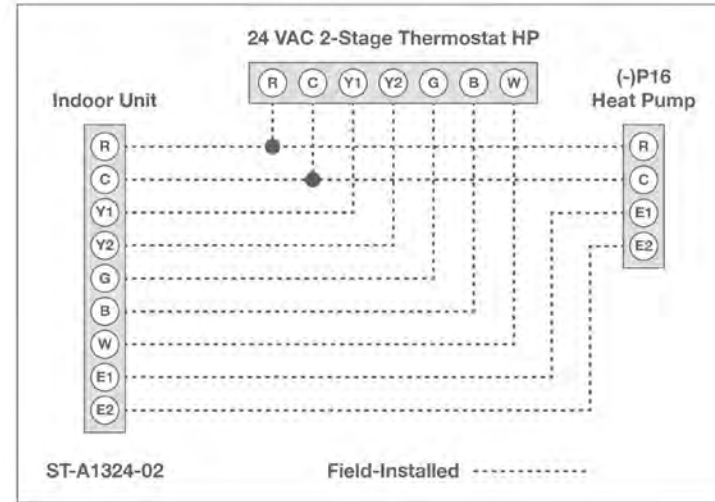



COMMISSIONING OUTDOOR UNIT: ECONET SMART THERMOSTAT

- No extra setup required
- You can further refine comfort settings. For example,
 - Defrost Terminate Temp
 - Heating/Cooling Airflow Trims
- These adjustments must be made at the EcoNet Smart Thermostat

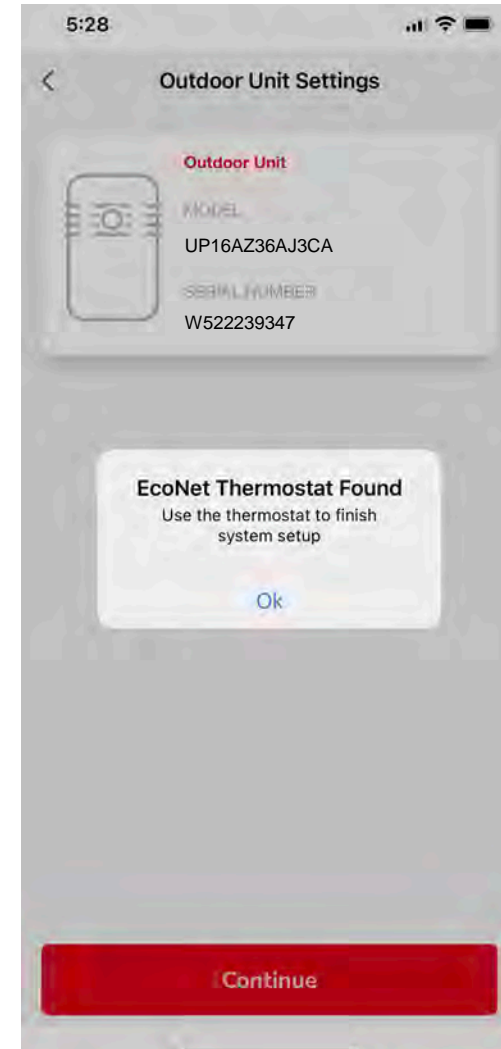
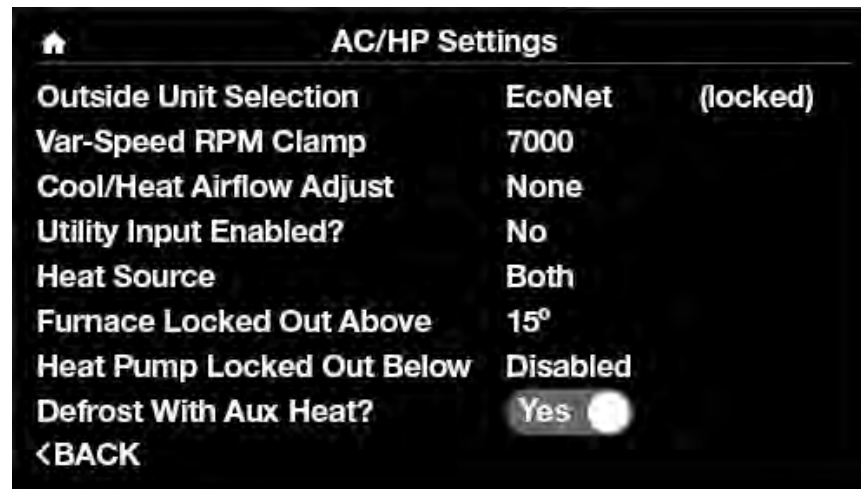



COMMISSIONING OUTDOOR UNIT: LEGACY (24V) THERMOSTAT

- Outdoor Unit must be wired communicating to indoor unit (R, C, E1, E2)
- Need to set the system up using the Contractor App
- The app will connect to UODC via Bluetooth
- Can further refine comfort settings after system is connected

Note: If you do install a unit, but for some reason can't configure it, the system will use the "default" model data from the board that was programmed at the factory.

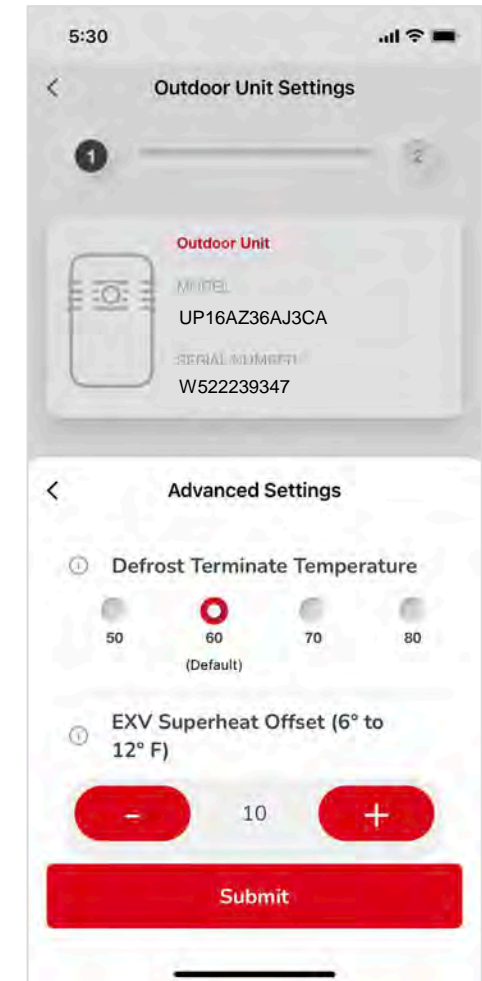
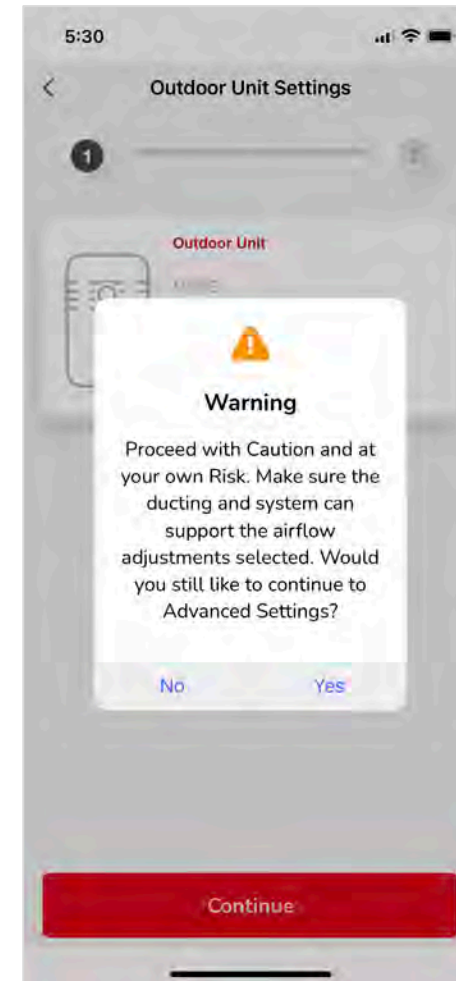
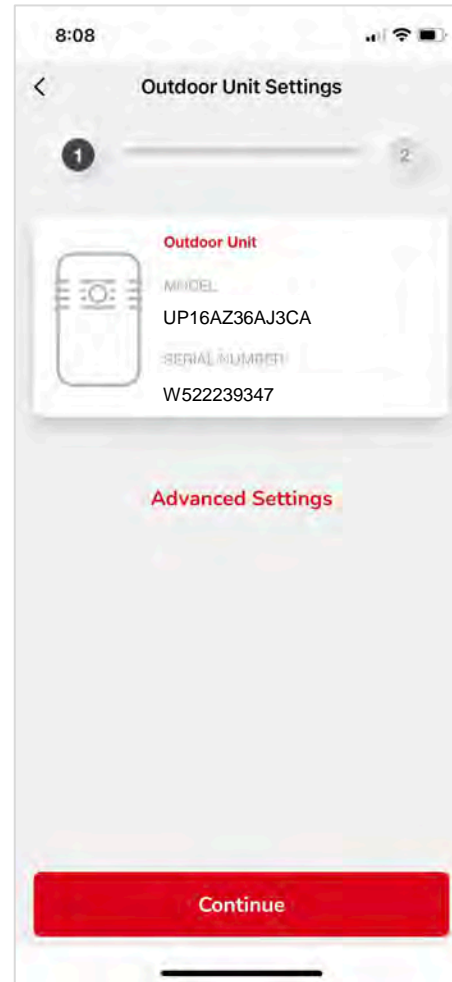



MID-TIER ECONET THERMOSTAT OPERATION

- On call – compressor ramps up to 45% capacity within 30 seconds.
- The EcoNet uses **demand based logic** to stage the unit between 45-70% or 100% capacity.
 - > 1°F demand will stage to line voltage
- Switch to line voltage:
 - Synchronize drive and line wave lengths (hertz)
Compressor will run at **3450 RPM** until the call is satisfied.
 - Cannot stage down from line voltage

Note: Fundamentally, EcoNet hasn't changed.

*AC example based on initial test data, when compared to base efficiency product

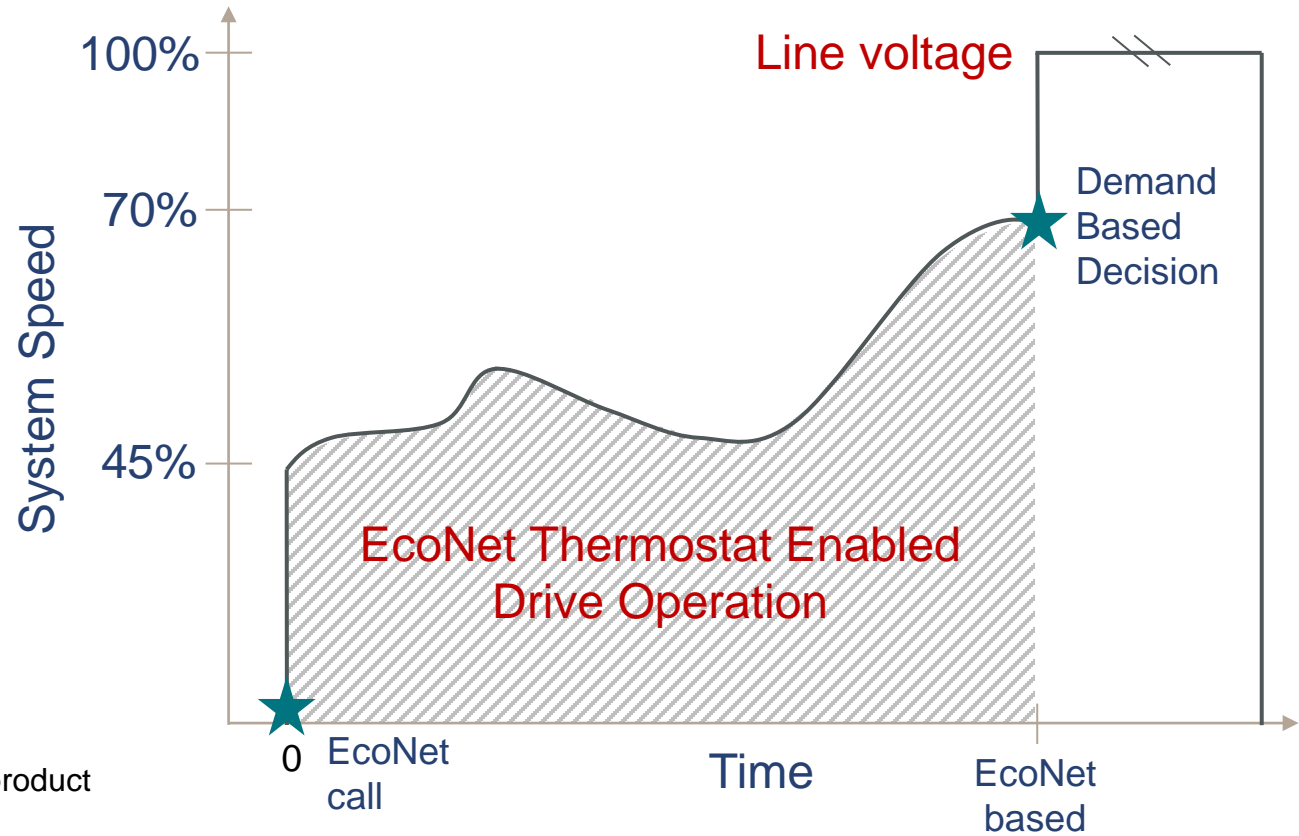



MID-TIER 24V LEGACY THERMOSTAT OPERATION

Y1 Call

- Compressor ramps up to 45% capacity
 - within 30 seconds.

Adaptive Learning Algorithm

- Determines when to move the system from 45% to 65% capacity based on previous cycle.
- Between 5 and 12 minutes
- 20 minute maximum @ 45%

Y2 Call:

- Switch to Line Voltage
 - Synchronize drive and line wave lengths (hertz)
 - Compressor will run at **3450 RPM** until the call is satisfied.
 - Cannot stage down from line voltage

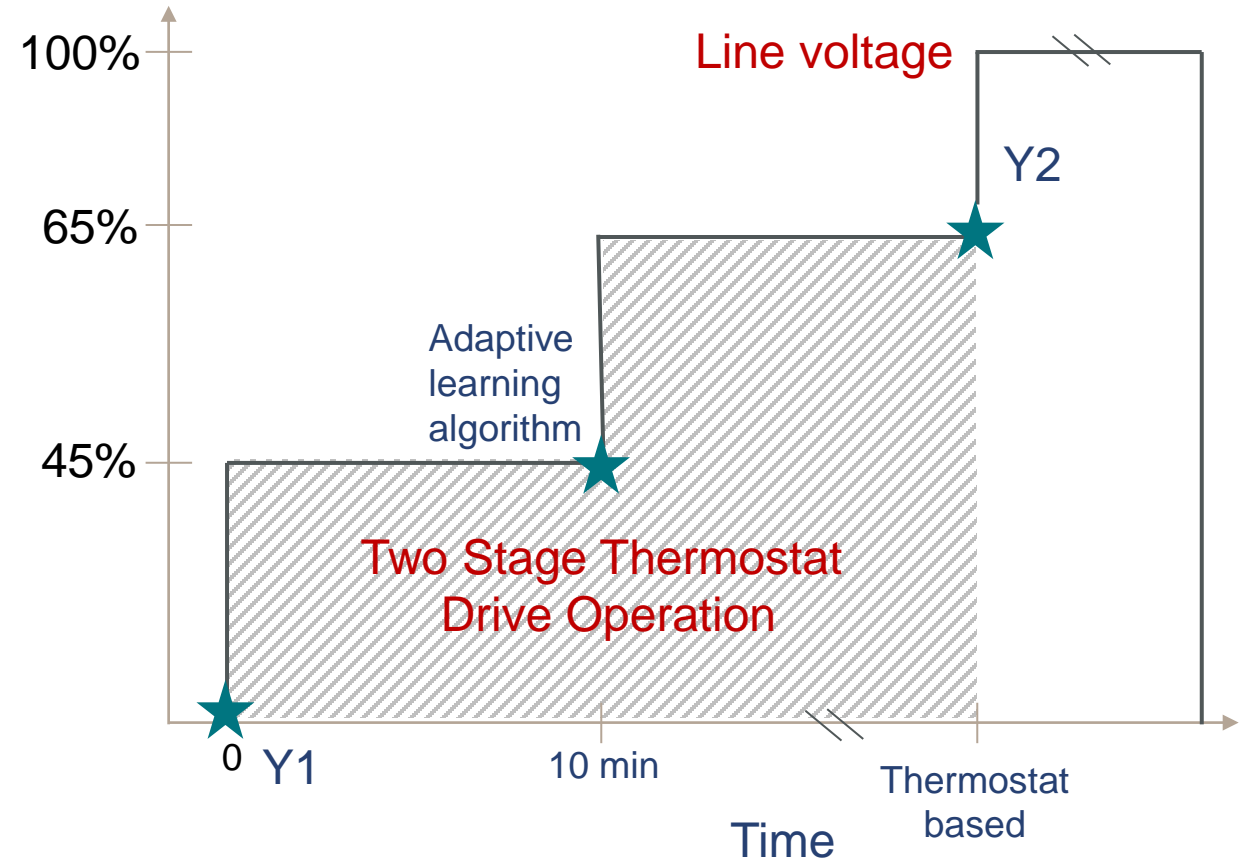



ADVANTAGES OF ECONET SMART THERMOSTAT

- ⚡ Less equipment cycling
- 🔧 Better diagnostics
- 🕒 Longer part load run times
- 💧 Better dehumidification
- 🌡️ Better temperature control
- 🔊 Decreased indoor fan noise
- ☁️ Connectivity
- 🔄 Auto-configuration
- 🌿 Customer carbon footprint

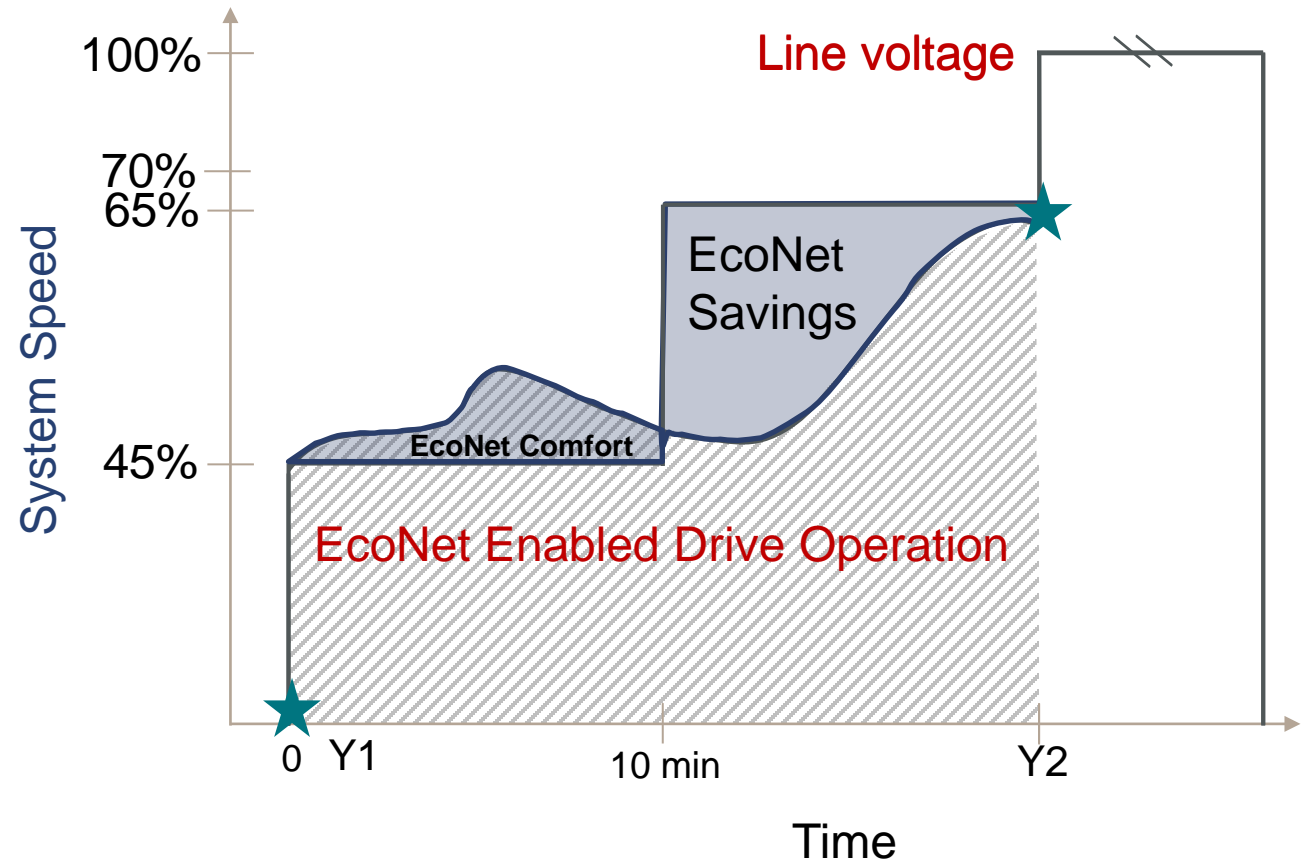



MID-TIER OPERATION – SEQUENCE OF OPERATION EXCEPTIONS

High Speed

Runs at high speed when one of the following occurs:

- OAT > 95°F or if OAT < 32°F
- Saturated liquid temp > 120°F
- Saturated suction temp < 0°F after 15 mins runtime

Pressure Relief Valve

- Opens to equalize the liquid and suction pressures
- Twin Rotary compressor won't start under a high differential pressure
 - Difference between liquid and suction pressure must be < 20 psi
 - If there is a differential > 20 psi, the lock timer will hold at 5 seconds
 - Additional information on slide 48





MID-TIER OPERATION – SEQUENCE OF OPERATION EXCEPTIONS (CONT'D)

EcoNet zoning

- 2 zones only
- Bypass must be used
 - Due to conditions (previous slide) that will force high speed operation

Oil return speed

- After 2 hours of accumulated run time at minimum compressor RPM, unit goes to 2400 RPM.
- Minimum runtime of 2 minutes before unit will shift to oil return speed
- Oil return speed runs for approx. 2 minutes





DEMAND DEFROST

Defrost Initiation

- Outdoor coil temperature is below 35°F (1.7°C).
- Compressor has operated for at least 34 minutes with the outdoor coil temperature below 35°F (1.7°C).
- UODC determines a defrost cycle is required based on the OAT and EVAPIN temperatures.

Defrost Cycle

- Reversing valve is de-energized.
- Outdoor fan motor is de-energized.
- Auxiliary heat is energized.





DEMAND DEFROST (CONT'D)

Defrost Termination

Coil temperature reaches the termination temperature or 14 minutes:

- Reversing valve will be energized.
- The outdoor fan motor is energized.
- Auxiliary heat is de-energized.
- The system returns to normal heating operation

Notes

- Mid-Tier units defrost at different RPMs:
 - If the system is running on drive, it will ramp to ~70%.
 - If running on the line, it will continue on the line (3450 RPM).
- If outdoor temperature thermistor fails, the UODC will defrost every 34 minutes of operation at coil temperature below 35°F.
- Defrost termination temperature is 60°F (15.6°C); can be changed using via the EcoNet Smart Thermostat
- If a call for heat is satisfied during a defrost cycle, the unit will continue defrost on the next heating call



MID-TIER TROUBLESHOOTING



DIAGNOSTIC CODES

- Alarms and Alerts identify where the fault occurred by looking at the suffix at the end of the alarm code.
- First letter (alarm/alert type)
 - **A** = Alarms (System shutdown)
 - **T** = Alerts (Not critical – unit will run)
- Last letter (alarm/alert location)
 - **_O** = Outdoor Unit
 - **_A** = Air Handler
 - **_F** = Furnace
 - **_C** = Communication
 - **_S** = System
 - **_Z** = Zoning
- Example:
 - **A953_O** is an **alarm** that occurred in the **Outdoor** unit.
 - You will know this because the **A** at the beginning stands for an **alarm** and the **_O** at the end identifies the fault having occurred in the **outdoor** unit.

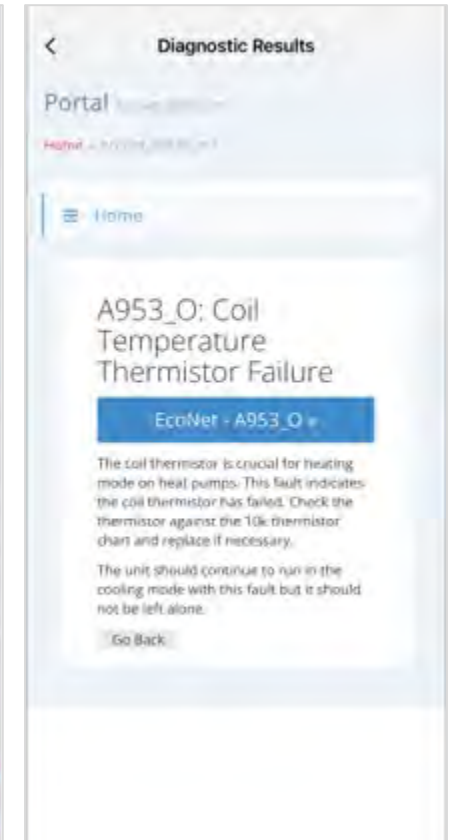
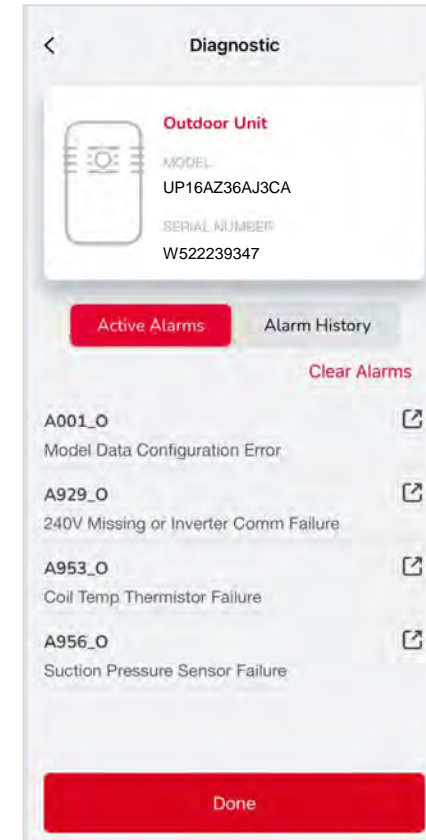

See Contractor App for EcoNet help pages *



TEST MODE

- Momentary press
 - Clears the lock timer to get the unit running under a normal cooling/heating request, given there is no Alarm.
 - The pressure differential still needs to be < 20 PSIG to start the unit.
- 3 second press (while unit is off)
 - “Bump” test
 - Turns the unit on for 1 minute in low cooling.
 - If liquid pressure > 500 or suction pressure < 50, turns off. If pressure differential > 100, goes to High Cooling. If pressure differential > 120 PSIG, turns off.
 - The drive may go to high speed directly under the usual conditions, outside temp > 95°F, saturated liquid temp > 120° F, high current draw (> 90%)
- 5 second press (while unit is in heat mode)
 - Forces defrost

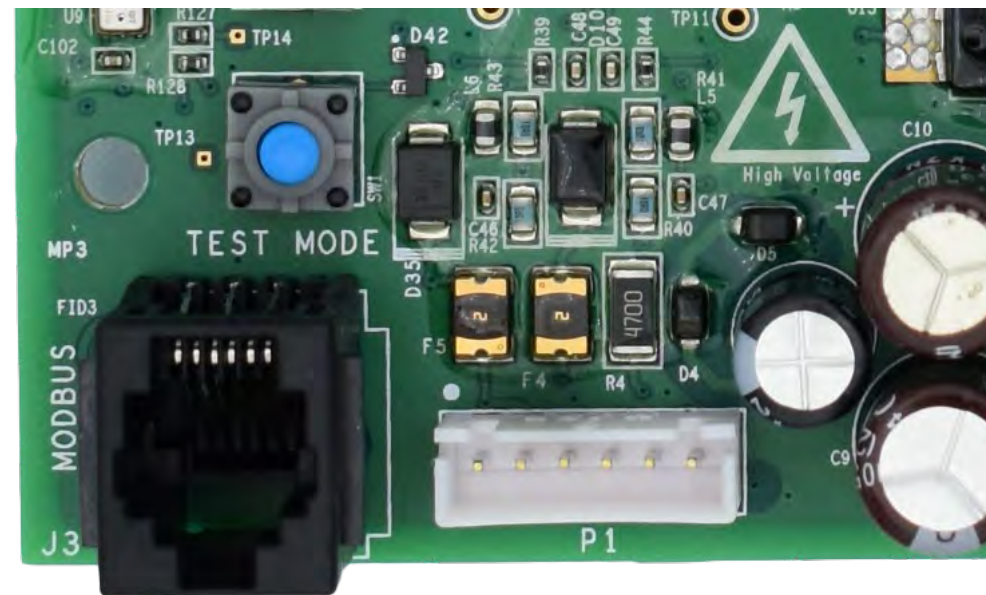

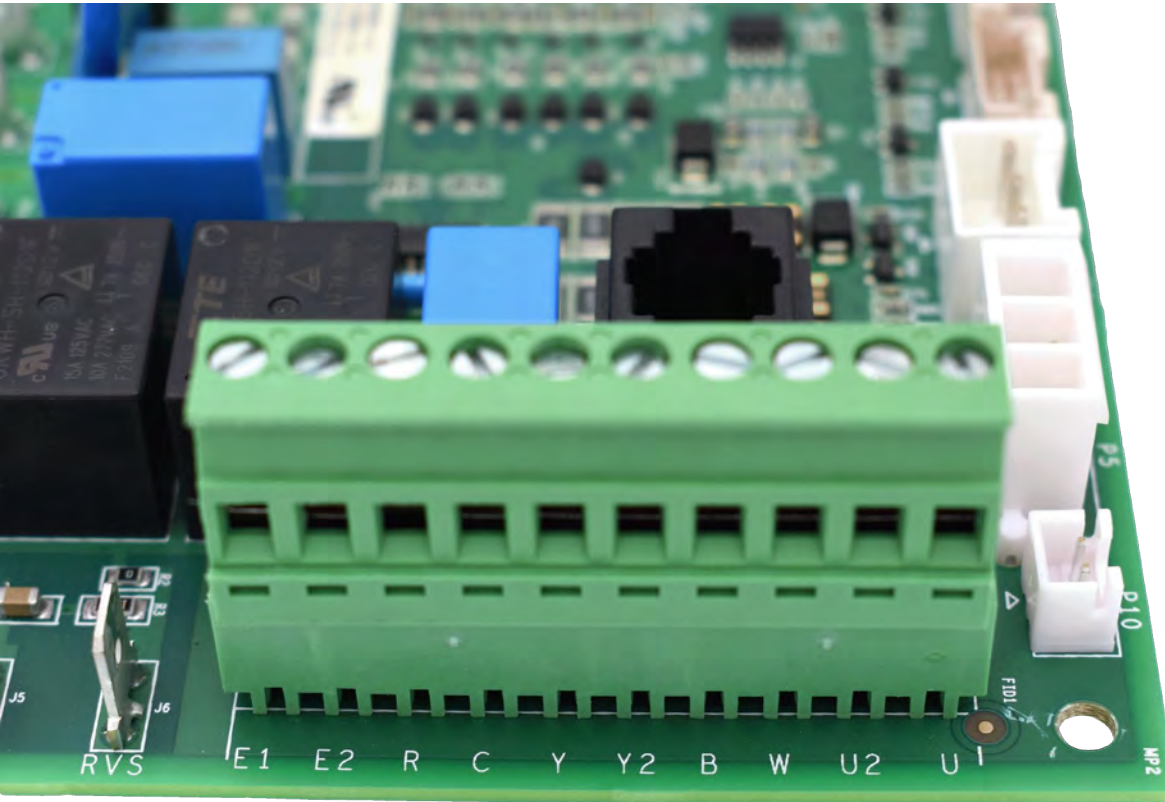

- EcoNet is an RS-485 serial bus, using two data wires (E1, E2) and a common (C). All devices have a green COM LED that should be blinking rapidly. Voltage readings:
- All devices disconnected, power applied to control:
 - E1 & E2 ~3 VDC
 - E1 & C ~3 VDC
 - E2 & C ~0 – 0.2 VDC
- Devices connected, power applied to control:
 - E1 & E2 ~1.0 – 3.5 VDC pulsating
 - E1 & C ~2.5 – 3.5 VDC pulsating
 - E2 & C ~0.1 – 1 VDC pulsating



MODBUS CABLE

- UODC gets power from both Indoor unit (R&C) and UODC (MODBUS)
 - Removing 24v from UODC will not fully de-energize it
 - A UODC without 24v will still have LEDs illuminated
- 18 VDC between black wire and black/blue wire

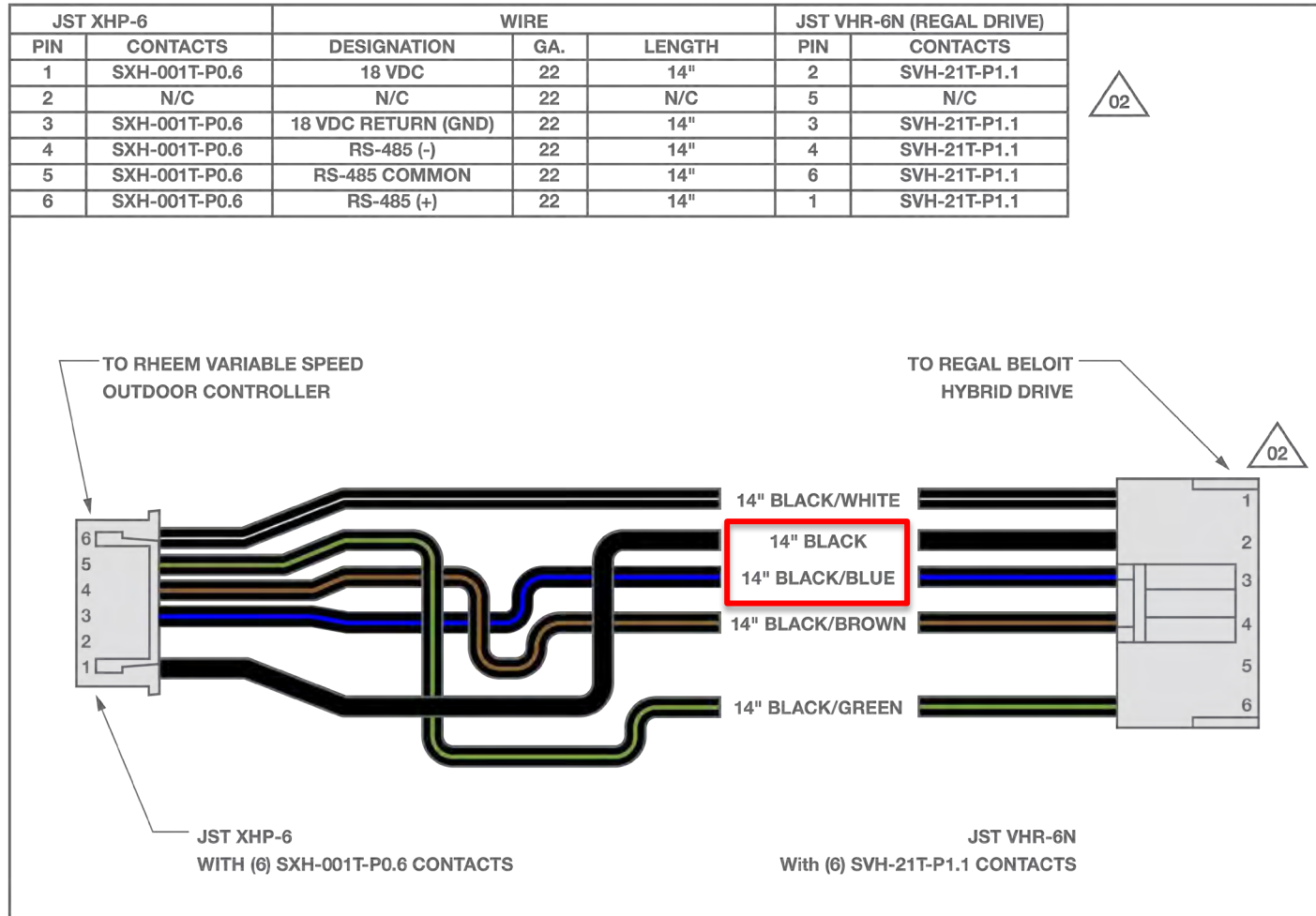



LINE OPERATING VOLTAGES

Line Operating Voltage

- Inverter Drive monitors voltage
- Operating voltage between L1 and L2 needs to be between 197VAC and 253VAC.
 - **Note:** In the event the voltage is greater than 253VAC, contact the local utility and have them reduce the voltage to the home.
- If line voltage > 265 VAC, unit will throw Overvoltage code
- If line voltage < 187 VAC, will throw Undervoltage code

Line Voltage

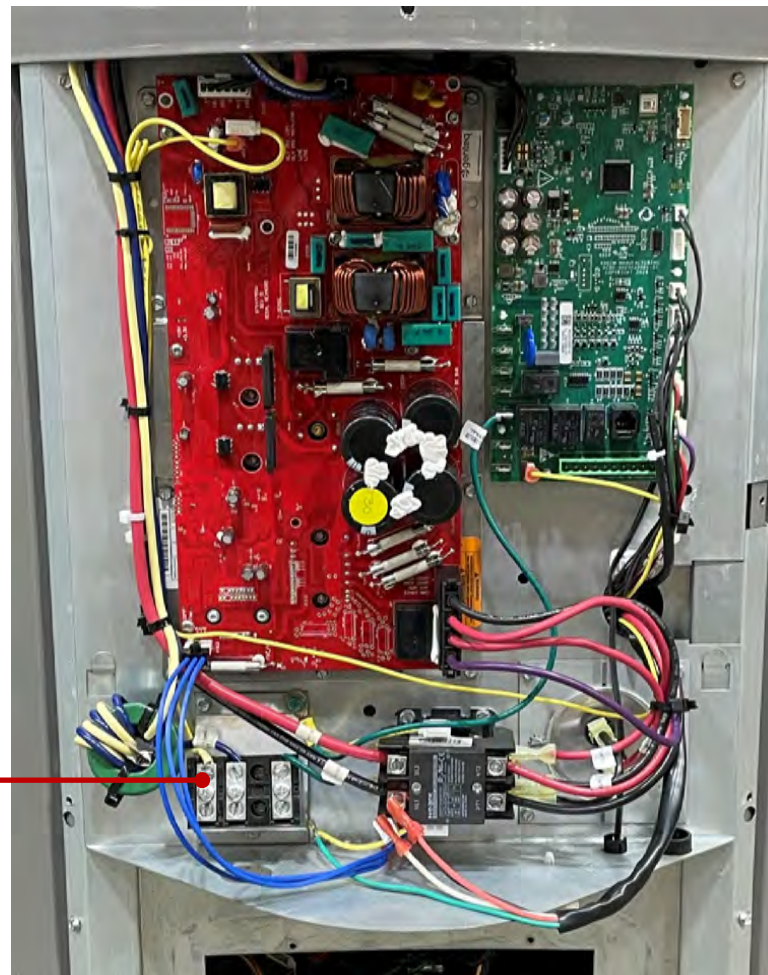



COMPRESSOR OVER TEMPERATURE PROTECTION

- If discharge line temp (DLT) reaches 235°F more than 30 seconds:
 - Fault code displayed
 - Compressor RPM is reduced until DLT < 200°F
- Once DLT < 200°F compressor ramps to command speed

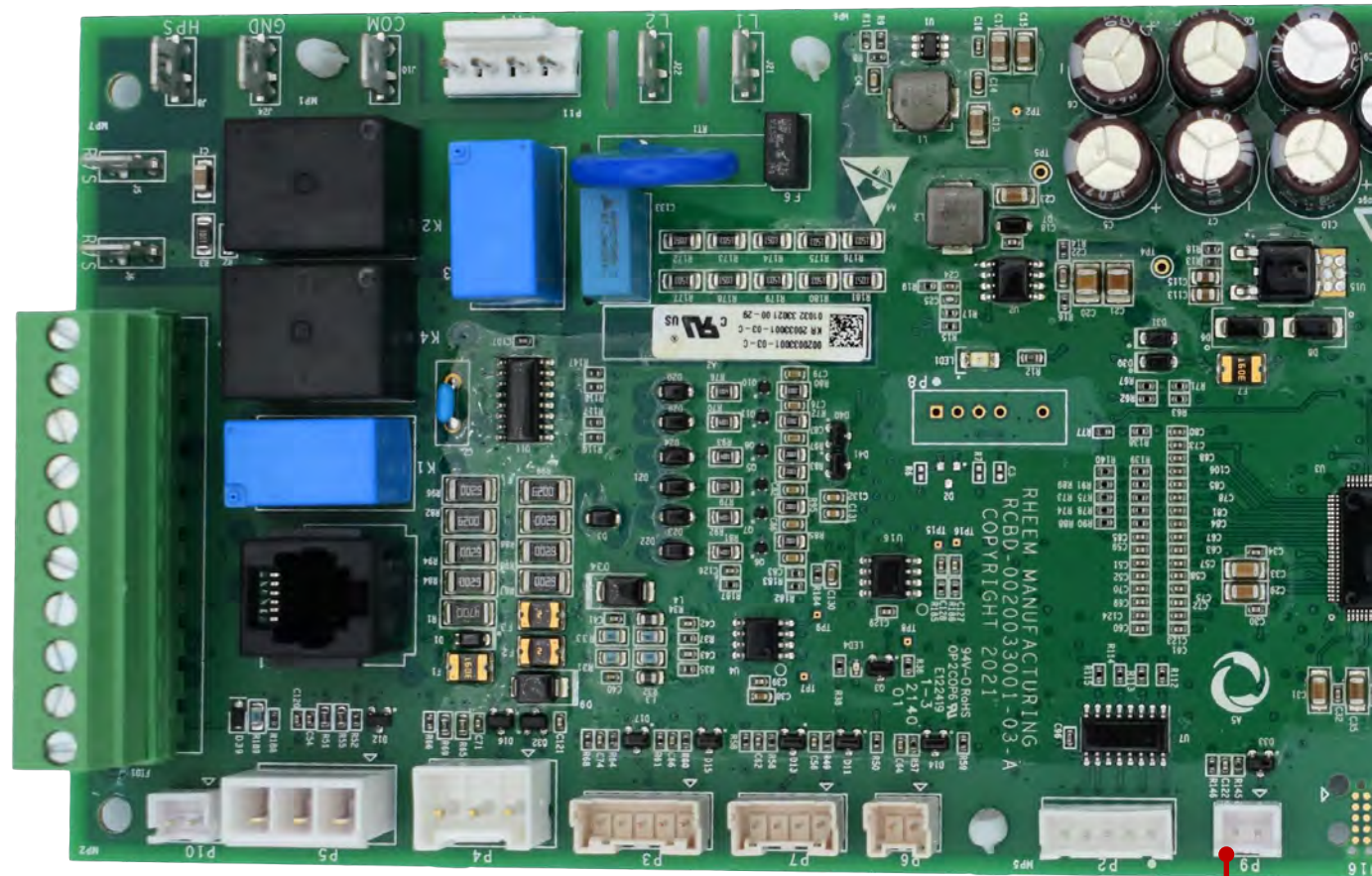

Discharge Line Temp.



HIGH PRESSURE SWITCH

- Connected directly to inverter
- Automatic reset
 - Opens: 610 PSI
 - Resets: 490 PSI
- Only considered during call for compressor operation

High Pressure Switch (HPS)

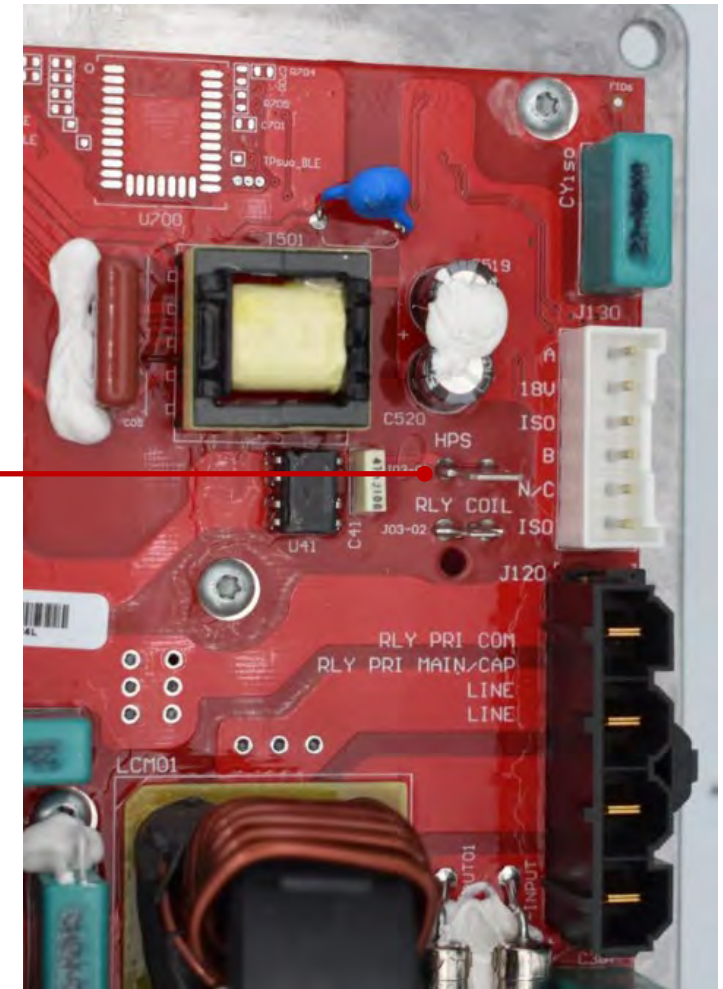



LOW PRESSURE SWITCH

Suction transducer permits different operating parameters:

- Cooling mode
 - Open: 50 psig
 - Close: 95 psig
- Heating mode
 - Open: 15 psig
 - Close: 40 psig

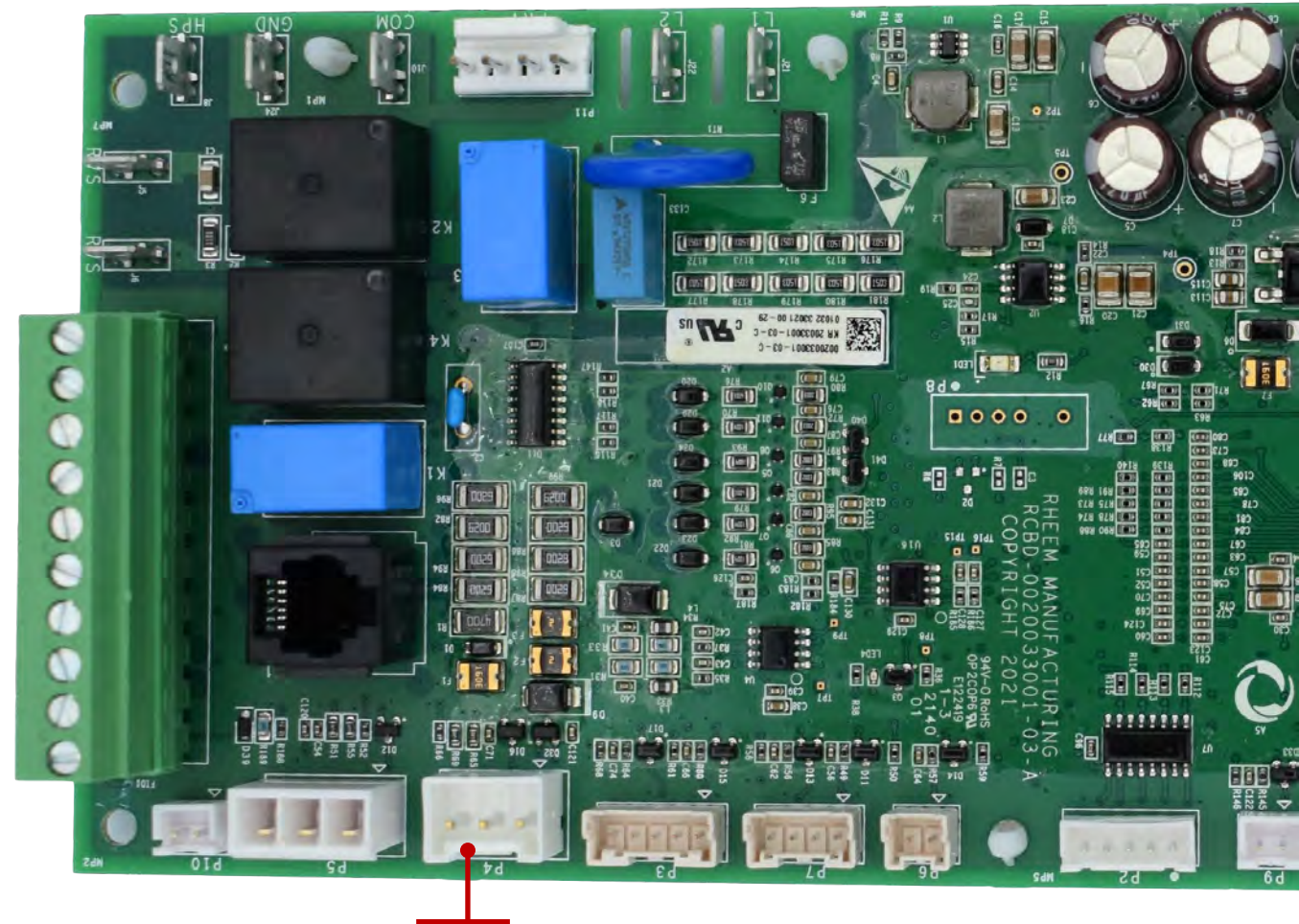

Low Pressure
(Suction Transducer)



PRESSURE RELIEF VALVE

- Solenoid valve from the discharge line to the suction line
 - Ensure less than 20 PSI differential
- Normally closed valve controlled by the UODC via a 24V plug
- Removable solenoid coil
- It will open during 5 min off cycle delay.
 - Should relieve pressure in 30 seconds
 - If pressure isn't relieved in 5 minutes, something is very wrong.
- If lockout timer is stuck at 5 seconds – pressure differential is greater than 20 PSI





DRIVE FAILS TO SYNC TO LINE

- Unit cannot go from the inverter to line voltage without synchronizing the wave lengths.
 - Before switching from inverter to line, drive has to synchronize the hertz (Hz) leaving the inverter to match the line voltage Hz.
 - Failure to synchronize will delay the jump to line voltage.
- Issues that could prevent quickly jumping from drive to the line voltage
 - Overcurrent
 - 3 strikes, then permanent lockout
 - Over temp (drive temperature)
 - 3 strikes, then permanent lockout
 - Open phase
 - 3 strikes, then permanent lockout
 - Contactor not closing
 - 3 strikes, then permanent lockout
 - Locked rotor fault
 - Compressor attempts to start every 5 minutes
 - 6 attempts before fault is displayed on EcoNet Smart Thermostat/App
 - Could result in a 30-minute delay
 - 6 strikes, then permanent lockout



HIGH-TIER BOARDS



HIGH-TIER CONTROL PANEL

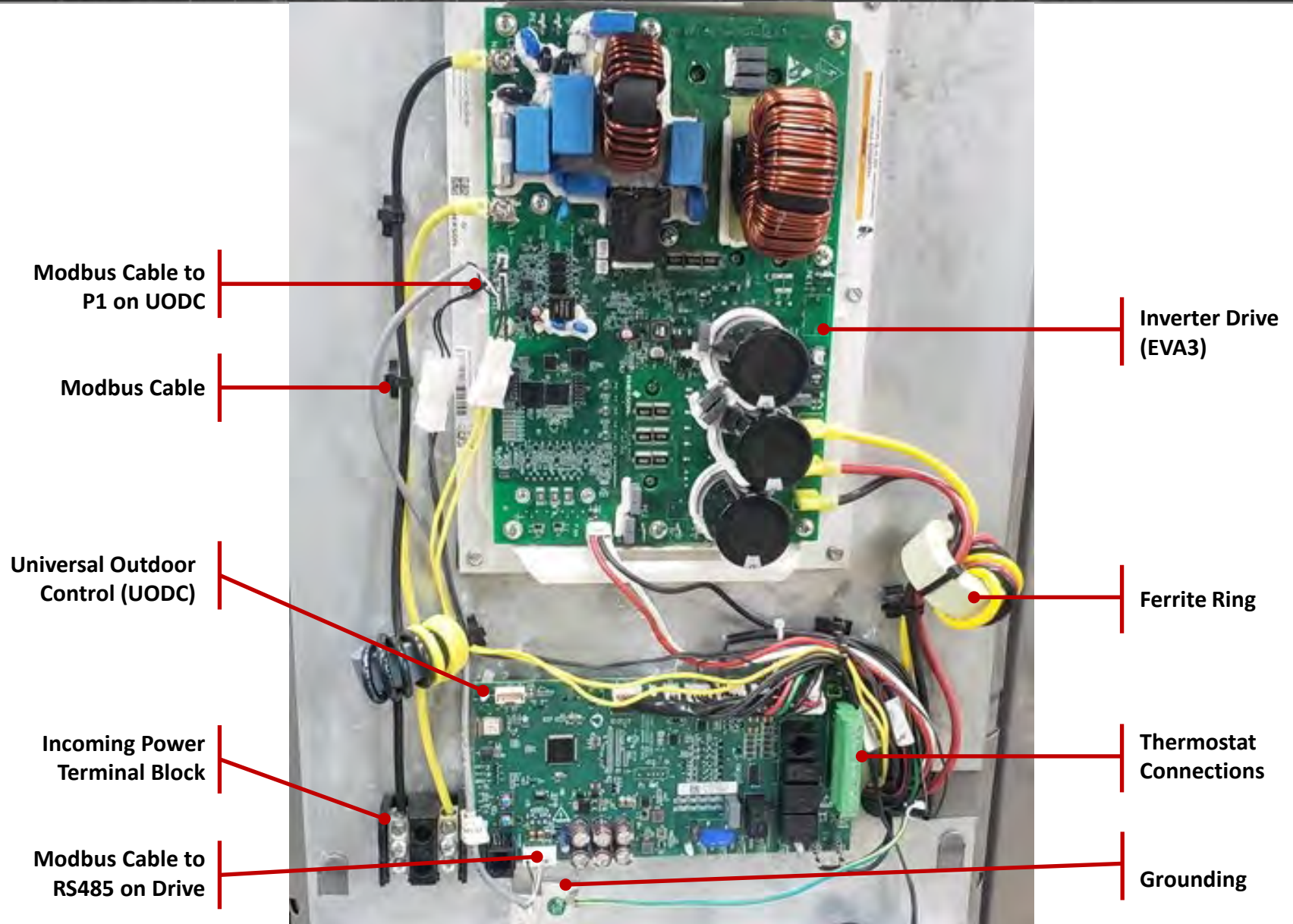



UNIVERSAL OUTDOOR CONTROL (UODC) – MID- & HIGH-TIER

- Name change from VSODU
- There is no memory card on the UODC
- No 7-segment display.
- All diagnostic codes are read through EcoNet or Contractor App
- Bluetooth Antenna
- If a UODC is replaced, it must be set up on-site via Bluetooth connection to the app
- Expanded information is in the Contractor App training
- Same sensors as previous models

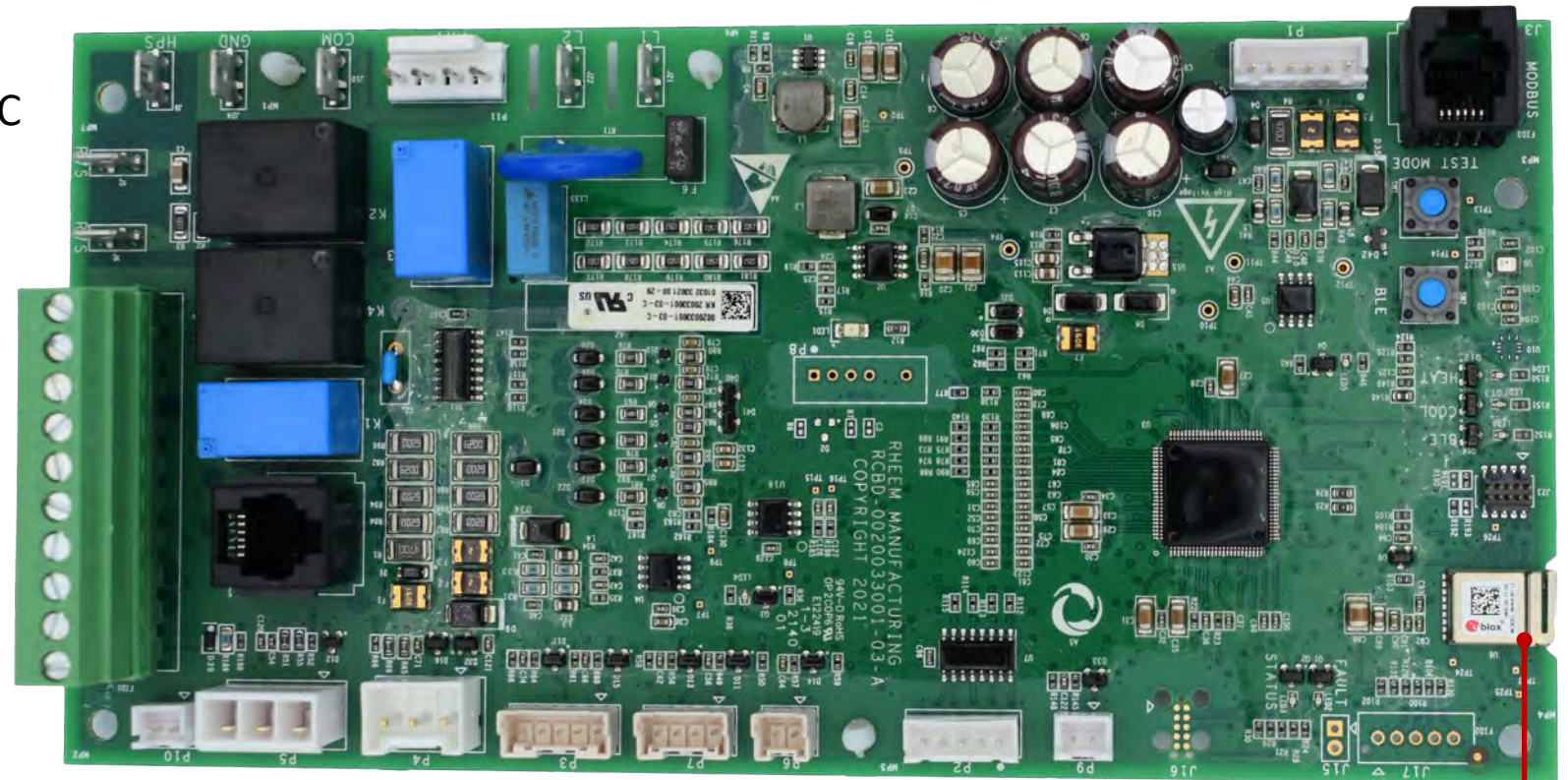

Bluetooth
Transmitter / Receiver



UODC COMPONENT CONNECTIONS

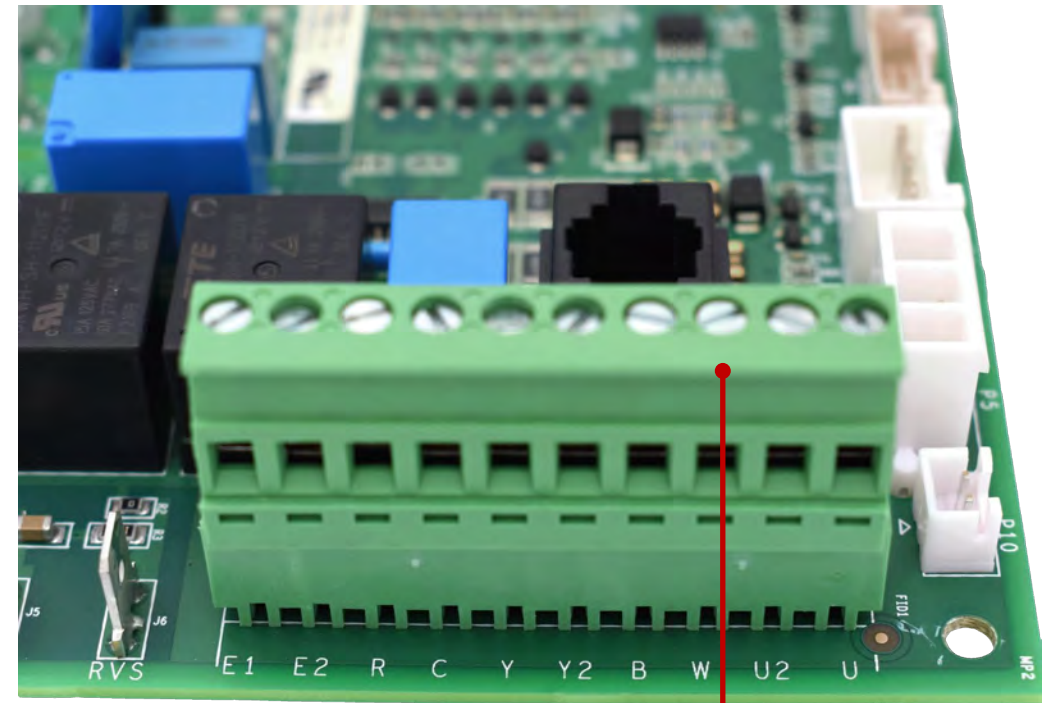
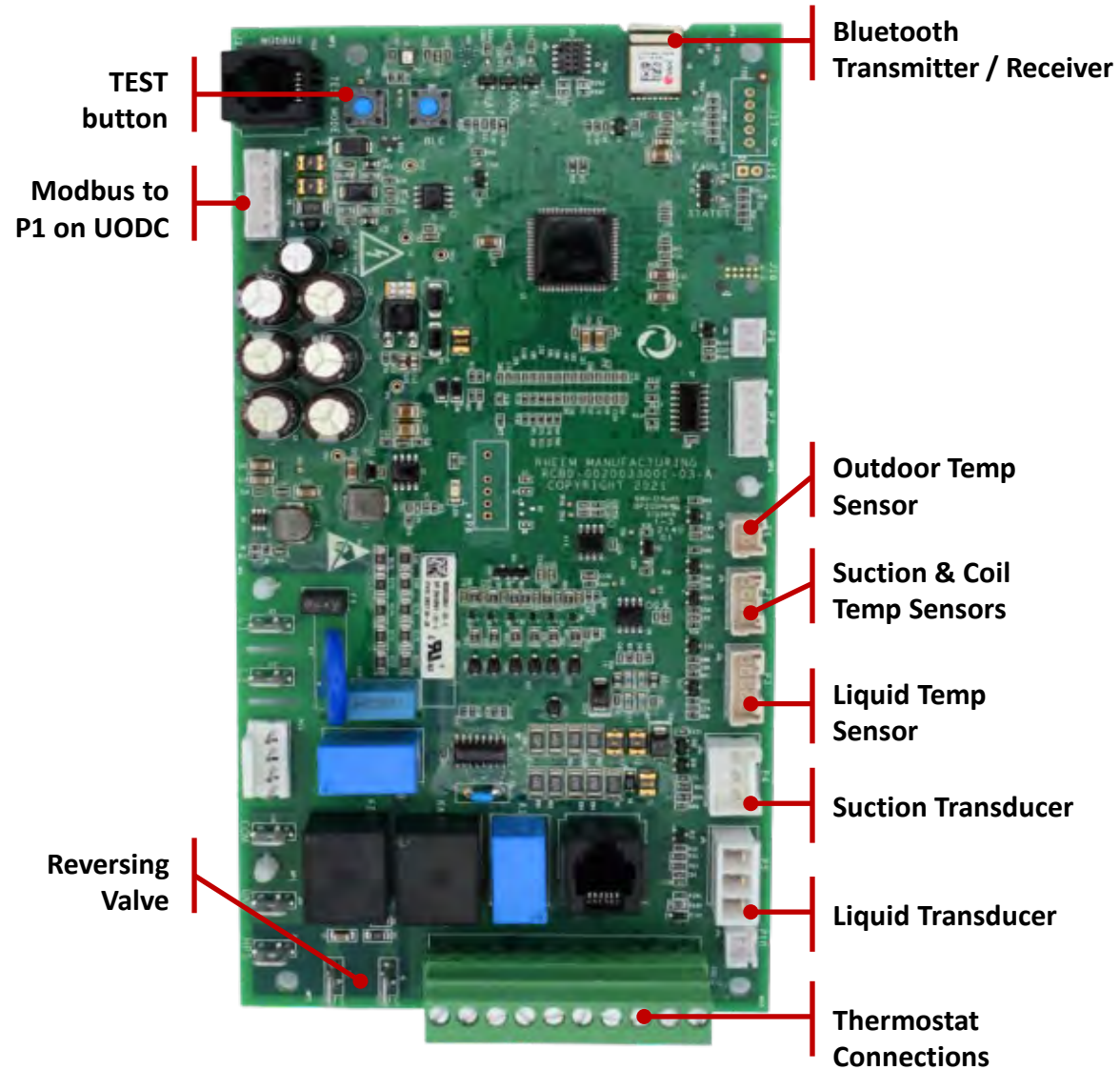



UODC LEDS

- **BLE - Green LED**
 - When blinking, Bluetooth is available to connect
 - When solid, Bluetooth is connected
- **Cool – Green LED**
 - Slow blink – Call present, but unit is in delay or lockout
 - Fast blink – one blink for every 10% of capacity being called for
 - e.g. 7 blinks for ~70%
 - 1 second rate of blink
 - 2 second rate of rest then repeats
- **Heat – Amber LED**
 - Blinks same as Cool
 - Defrost – Heat and Cool LEDs alternate every one second

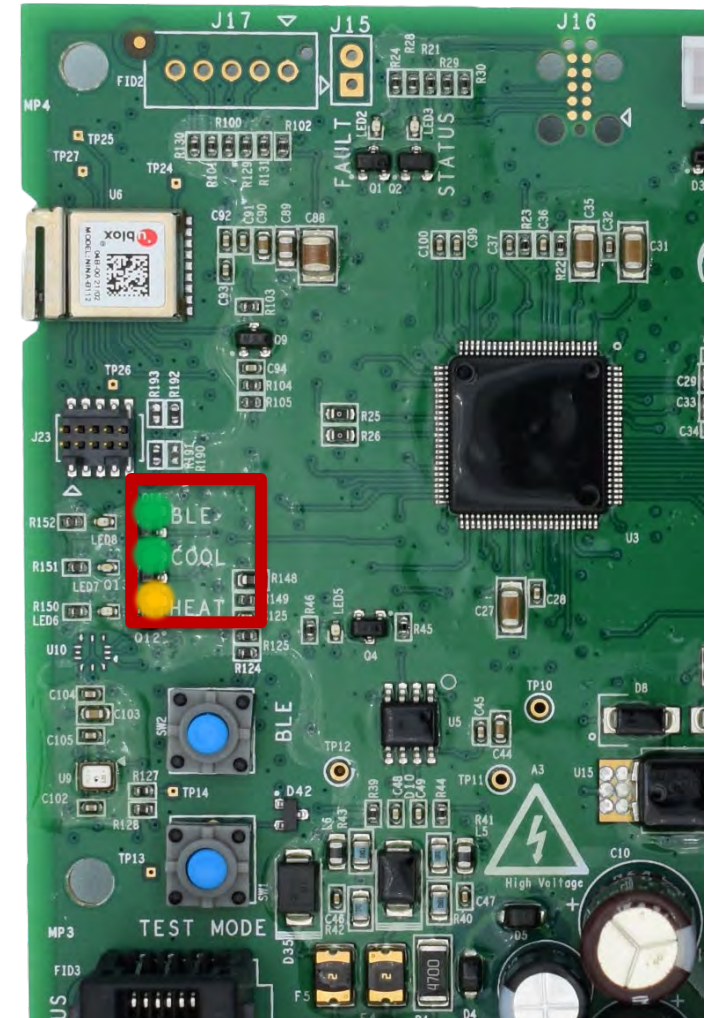



HIGH-TIER HP – WIRING DIAGRAM

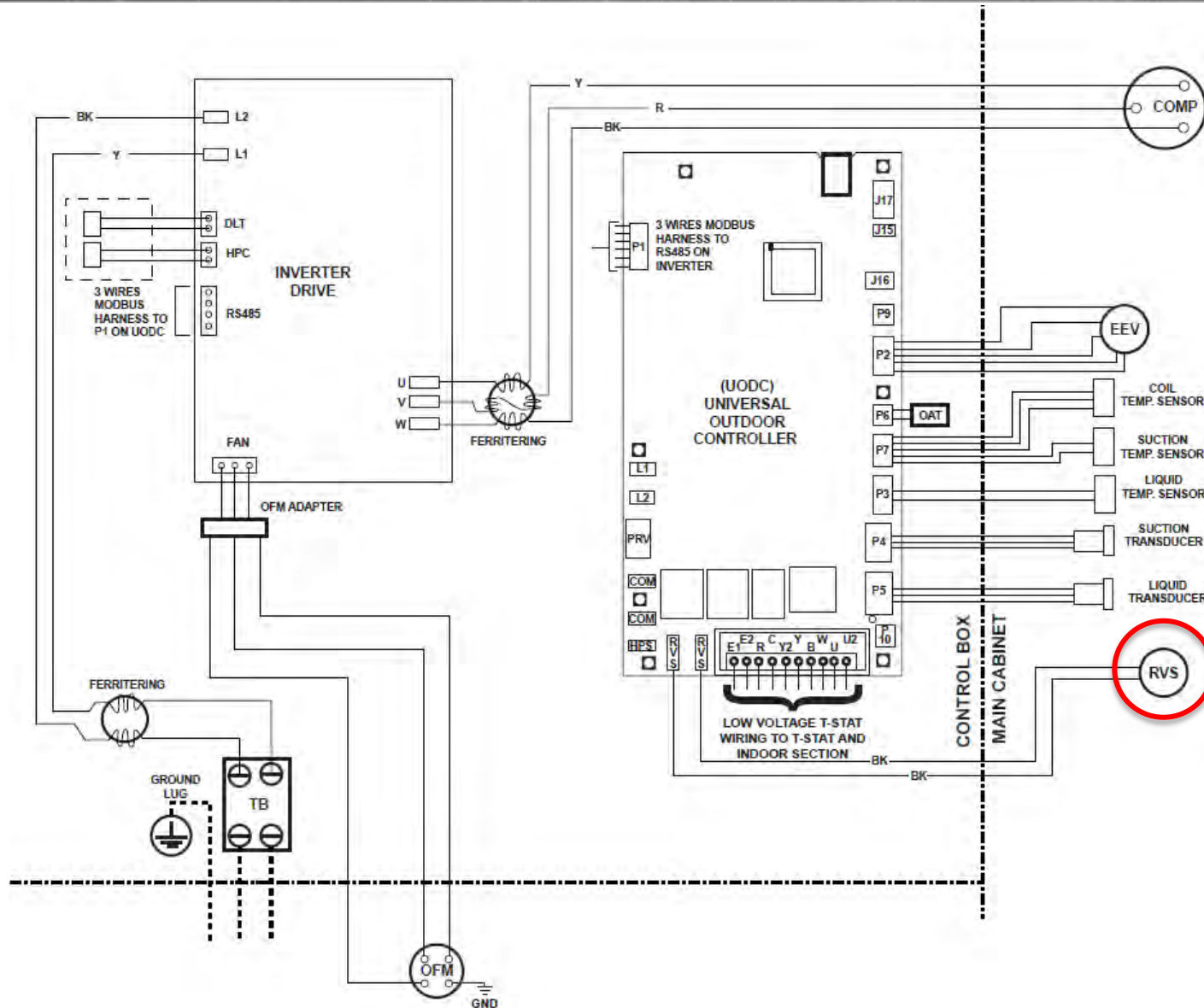

WIRING INFORMATION

LINE VOLTAGE

- FACTORY STANDARD
- FACTORY OPTION
- FIELD INSTALLED

LOW VOLTAGE

- FACTORY STANDARD
- FIELD INSTALLED
- REPLACEMENT WIRE

-MUST BE THE SAME SIZE AND TYPE OF INSULATION AS ORIGINAL (105C. MIN.)

WARNING

-CABINET MUST BE PERMANENTLY GROUNDED AND CONFORM TO I.E.C., N.E.C., C.E.C., NATIONAL WIRING REGULATIONS, AND LOCAL CODES AS APPLICABLE.

WIRE COLOR CODE

- | | | |
|--------------|--------------|---------------|
| BK.....BLACK | G.....GREEN | PR.....PURPLE |
| BR.....BROWN | G Y.....GRAY | R.....RED |
| BL.....BLUE | O.....ORANGE | W.....WHITE |
| | | Y.....YELLOW |

COMPONENT CODES

- | | |
|------|------------------------------|
| CAP | CAPACITOR |
| COM | COMMON |
| COMP | COMPRESSOR |
| DLT | DISCHARGE LINE THERMISTOR |
| EVAP | COIL TEMP |
| EEV | ELECTRONIC EXPANSION VALVE |
| GND | GROUND |
| HPC | HIGH PRESSURE CONTROL |
| HPS | HIGH PRESSURE SWITCH |
| LPT | LIQUID PRESSURE TRANSDUCER |
| OAT | OUTDOOR AMBIENT TEMPERATURE |
| OFM | OUTDOOR FAN MOTOR |
| OLT | OUTDOOR LIQUID TEMPERATURE |
| OST | OUTDOOR SUCTION TEMPERATURE |
| PRV | PRESSURE RELIEF VALVE |
| RVS | REVERSING VALVE SOLENOID |
| SPT | SUCTION PRESSURE TEMPERATURE |
| TB | TERMINAL BLOCK |



THERMOSTAT WIRING - ECONET

- Requires continuous 18 AWG thermostat wire.
 - Do not use phone cord to connect indoor and outdoor units. This will damage the controls.
- The EcoNet™ control system requires four control wires for unit operation:
 - R 24 VAC
 - C 24 VAC common
 - E1 Communications
 - E2 Communications
- The EcoNet™ enabled air handler or furnace is equipped with a 24-volt, 40 or 50 VA transformer for proper system operation. See the wiring diagram below for low voltage wiring connections.
- U, U2 terminals can be used for utility load shedding
 - Must be programmed at EcoNet Smart Thermostat or app

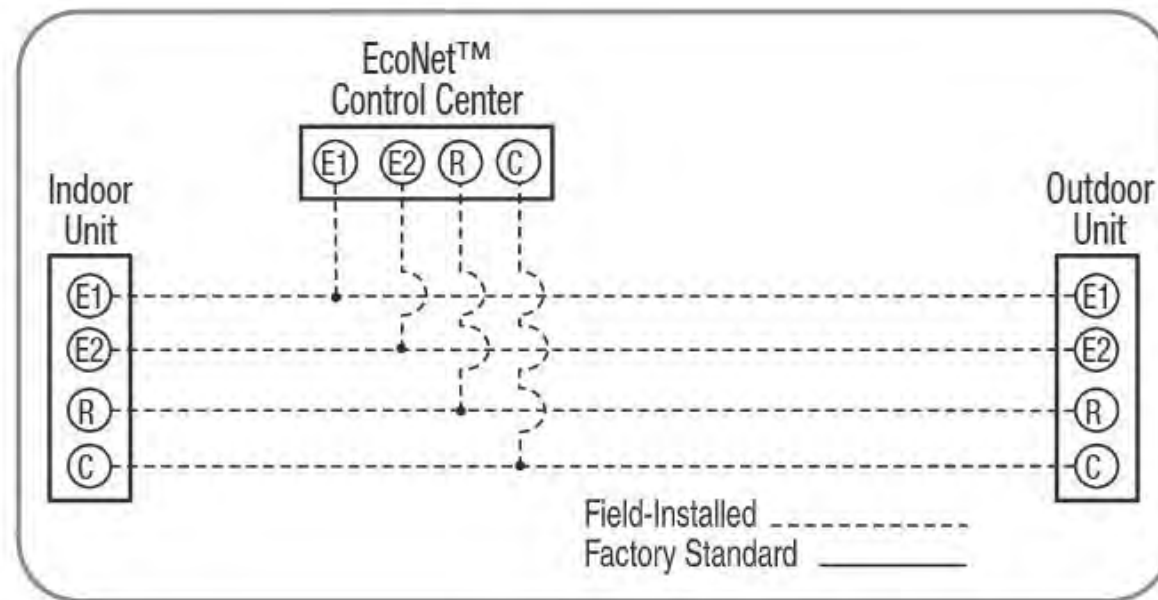



THERMOSTAT WIRING - LEGACY

- **For emergencies only, outdoor unit can be wired legacy**
 - System will operate as a single stage unit
- Requires continuous 18 AWG thermostat wire
 - Do not use phone cord to connect indoor and outdoor units. This will damage the controls.
- Thermostat control wiring requires a minimum of five (5) wires for proper heat pump or four (4) for air conditioner operation
 - R – 24 VAC (AC/HP)
 - C – 24 VAC common (AC/HP)
 - Y1 – 1st stage compressor (AC/HP)
 - Y2 – 2nd stage compressor (AC/HP)
 - B – Heat pump operation (HP)
 - W – Supplemental heat during defrost cycle (AC/HP)

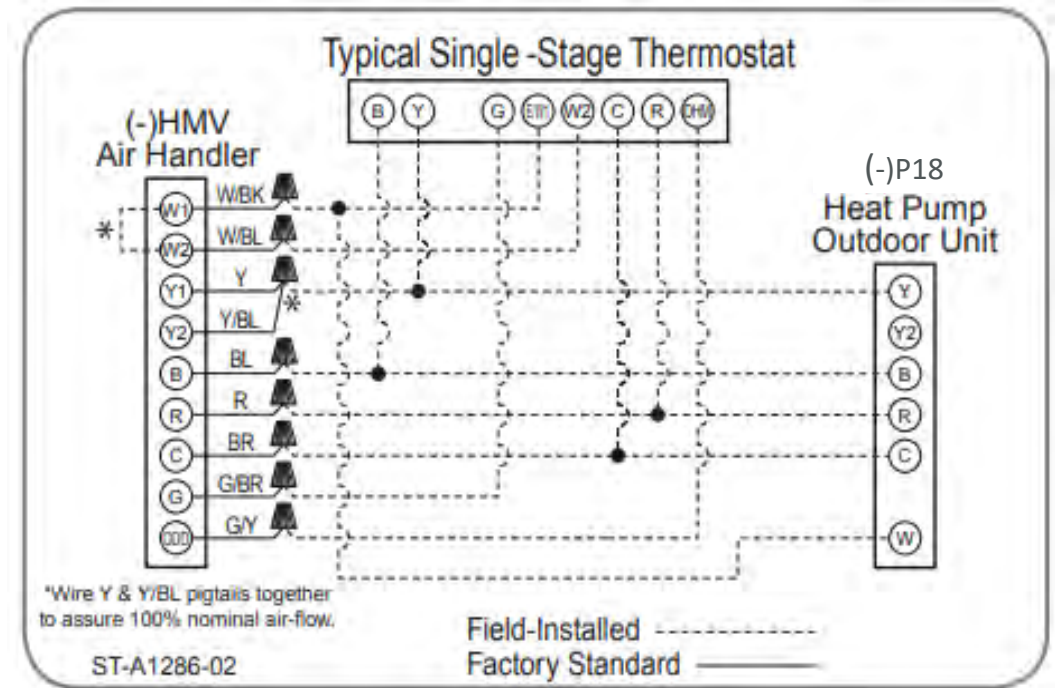



COMMISSIONING OUTDOOR UNIT: ECONET SMART THERMOSTAT

- No extra setup required
- You can further refine comfort settings. For example,
 - Defrost Terminate Temp
 - Heating/Cooling Airflow Trims
- These adjustments must be made at the EcoNet Smart Thermostat

AC/HP Settings		
Outside Unit Selection	EcoNet	(locked)
Var-Speed RPM Clamp	7000	
Cool/Heat Airflow Adjust	None	
Utility Input Enabled?	No	
Heat Source	Both	
Furnace Locked Out Above	15°	
Heat Pump Locked Out Below	Disabled	
Defrost With Aux Heat?	Yes	<input checked="" type="checkbox"/>
<BACK		





COMMISSIONING OUTDOOR UNIT: LEGACY (24V) THERMOSTAT

- **Not Recommended**
- Need to set the system up using the Contractor App
- The app will connect to UODC via Bluetooth
- Can further refine comfort settings after system is connected

Note: If you do install a unit, but for some reason can't configure it, the system will use the "default" model data from the board that was programmed at the factory.

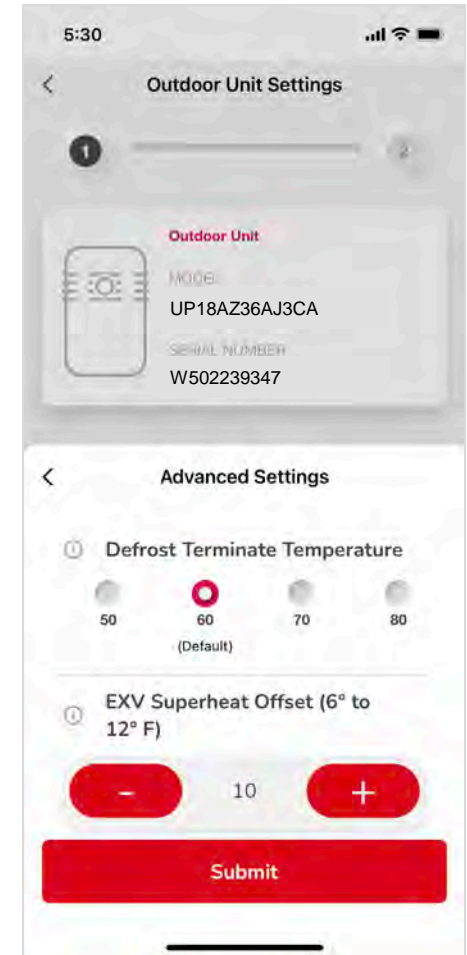
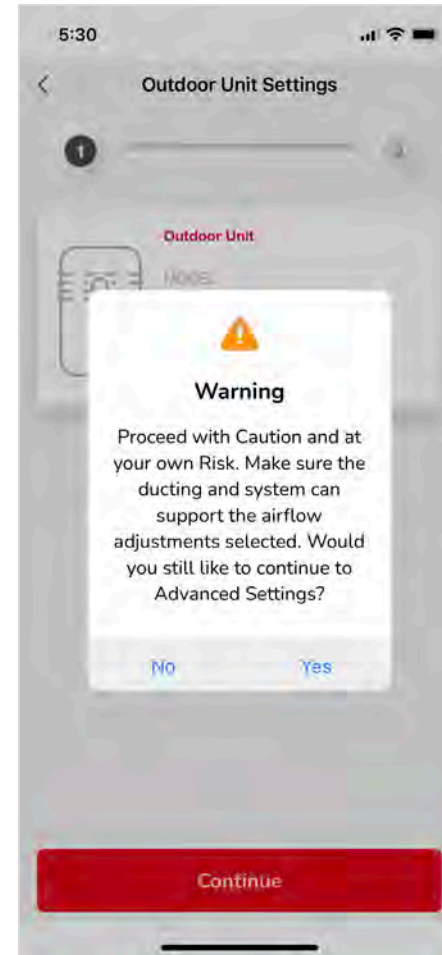
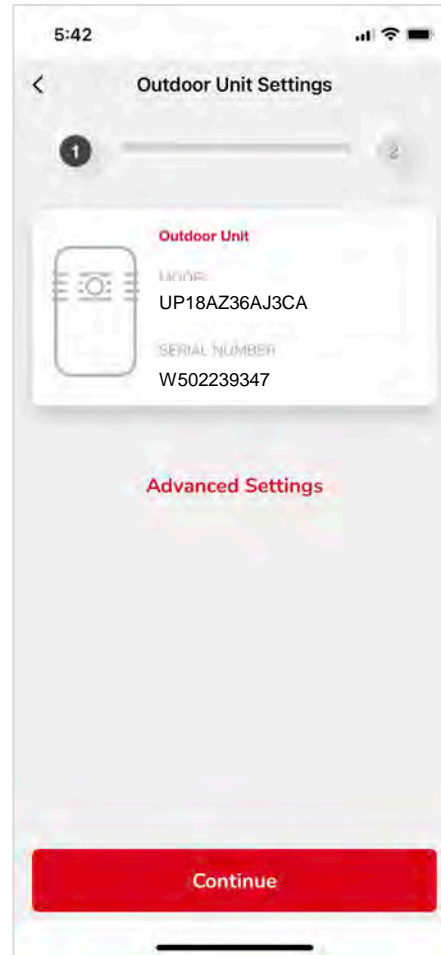



HIGH-TIER OPERATION

- The UODC control board will communicate to the inverter drive to begin system operation at the speed commanded by the EcoNet® Smart Thermostat.
- The drive will not start with Alarms present
- Emergency Operation
 - Wiring the system with conventional 24V wiring and thermostat will cause it to operate as a single-stage system at nominal capacity.
 - 24000 BTU
 - 36000 BTU
 - 48000 BTU
 - 60000 BTU





EVA3 STARTUP SEQUENCE

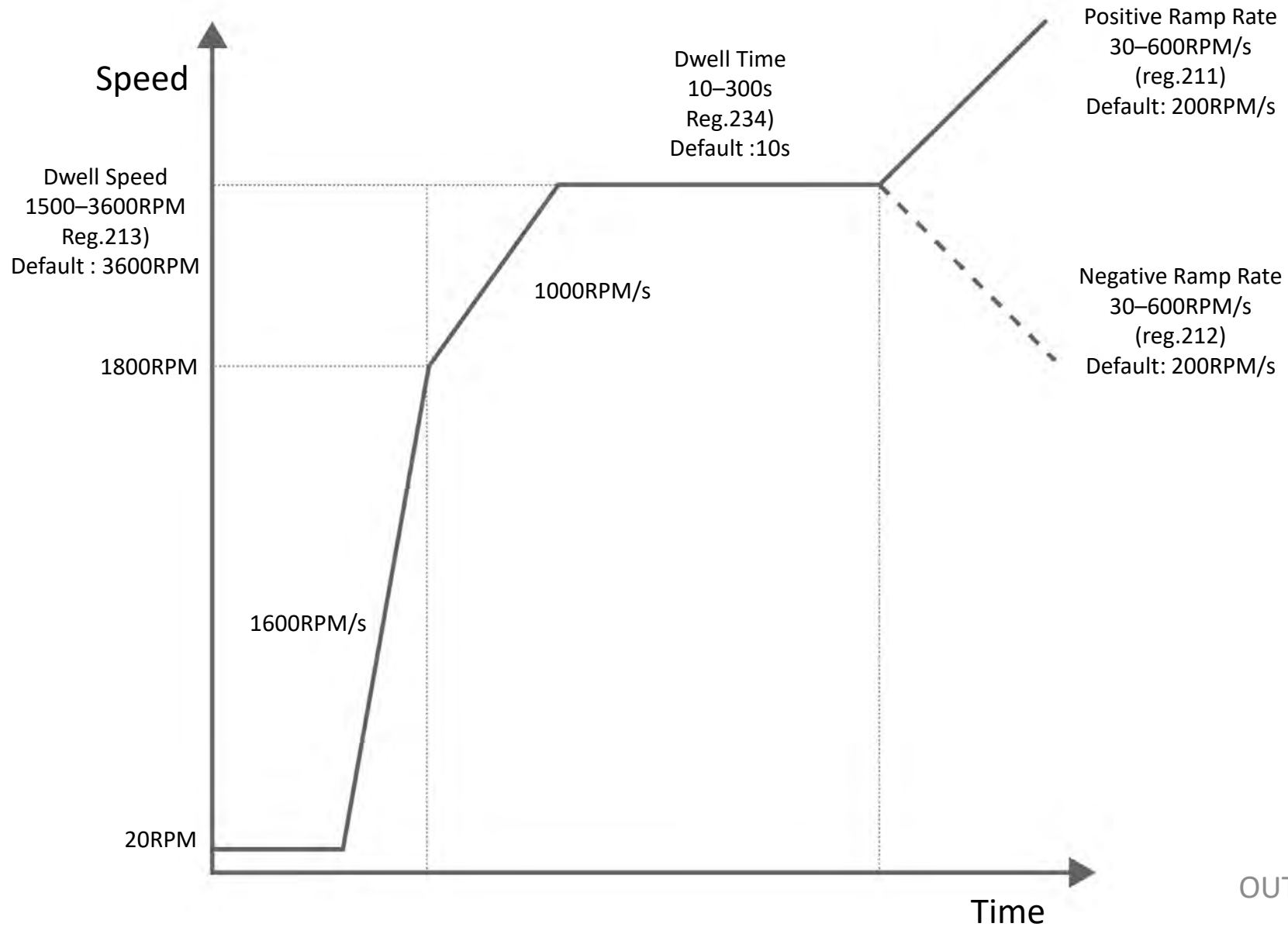



EVA3 SHUTDOWN SEQUENCE

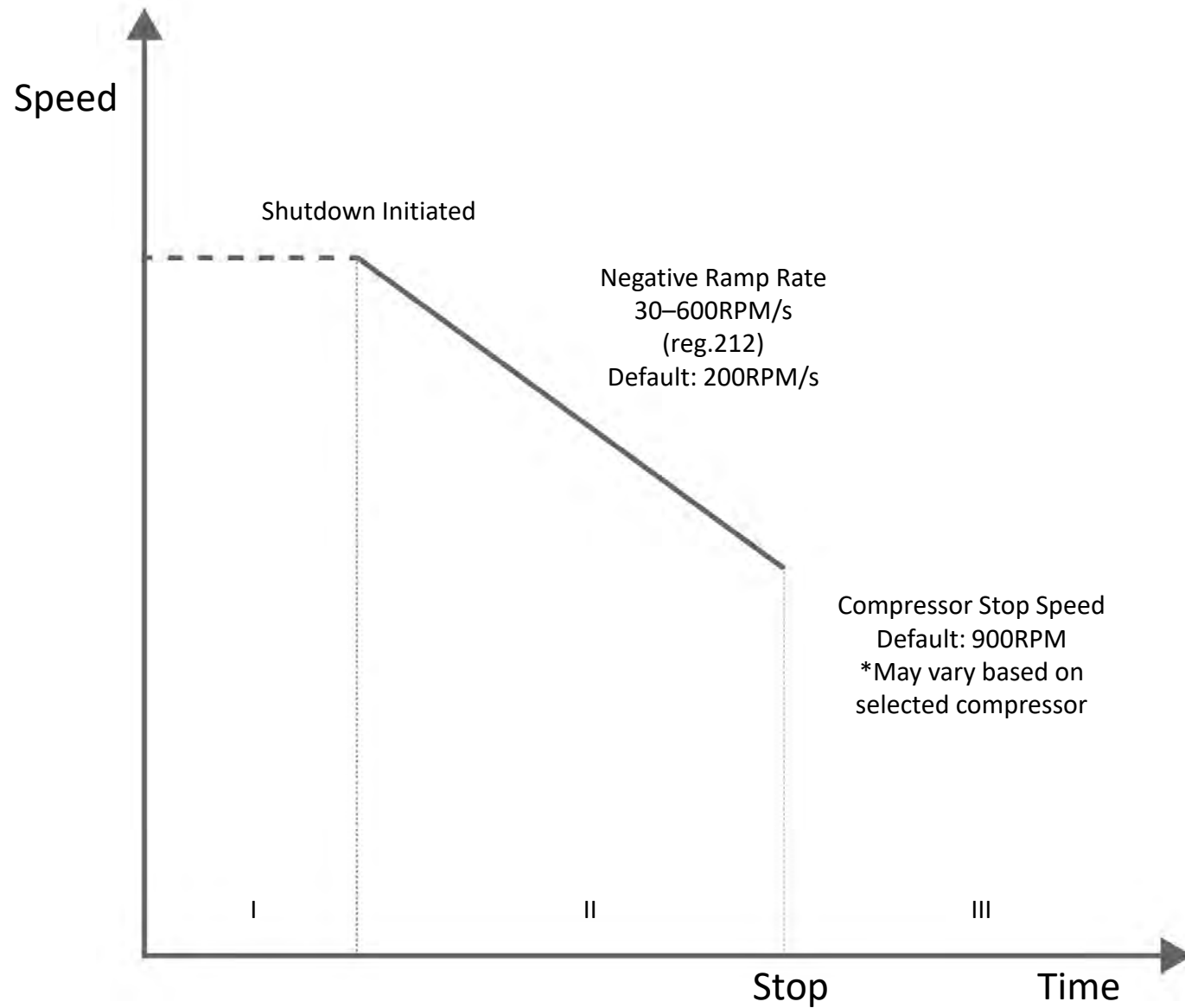



HIGH-TIER OPERATIONAL EXCEPTIONS

- Overdrive mode can increase compressor speed to over 100% capacity if needed
 - Available in both Heating and Cooling
- RPM clamp can be utilized to limit compressor RPMs
 - Available through Bluetooth or EcoNet thermostat





DEFROST SEQUENCE OF OPERATION – HIGH-TIER...

Defrost Initiation:

- Outdoor coil temperature is below 35°F (1.7°C).
- Compressor has operated for at least 34 minutes with the outdoor coil temperature below 35°F (1.7°C).
- UODC determines a defrost cycle is required based on the OAT and EVAPIN temperatures.

Defrost Cycle:

- The compressor speed is ramped to reversing valve switching speed for 30 seconds before the valve is deenergized.
- Reversing valve is de-energized
- Outdoor fan motor is de-energized.
- Auxiliary heat is energized.

Defrost Termination:

- Coil temperature reaches the termination temperature or 14 minutes elapsed
- The compressor speed is ramped to reversing valve switching speed for 30 seconds before the valve is energized.
- Reversing valve will be energized.
- The outdoor fan motor is energized.
- Auxiliary heat is de-energized.
- Compressor will ramp to oil circulation speed for 6 minutes
- The system returns to normal heating operation

NOTES:

- Mid-Tier units defrost at operating RPM (there is no specific speed for rev valve shift)
- If outdoor temperature thermistor fails, the UODC will defrost every 34 minutes of operation at coil temperature below 35°F.
- Forced termination temperature is 60°F (15.6°C); can be changed using Bluetooth connection to the UODC or via the EcoNet Smart Thermostat



HIGH-TIER TROUBLESHOOTING



DIAGNOSTIC CODES

- Alarms and Alerts identify where the fault occurred by looking at the suffix at the end of the alarm code.
- First letter (alarm/alert type)
 - **A** = Alarms (System shutdown)
 - **T** = Alerts (Not critical – unit will run)
- Last letter (alarm/alert location)
 - **_O** = Outdoor Unit
 - **_A** = Air Handler
 - **_F** = Furnace
 - **_C** = Communication
 - **_S** = System
 - **_Z** = Zoning
- Example:
 - **A953_O** is an **alarm** that occurred in the **Outdoor** unit.
 - You will know this because the **A** at the beginning stands for an **alarm** and the **_O** at the end identifies the fault having occurred in the **outdoor** unit.

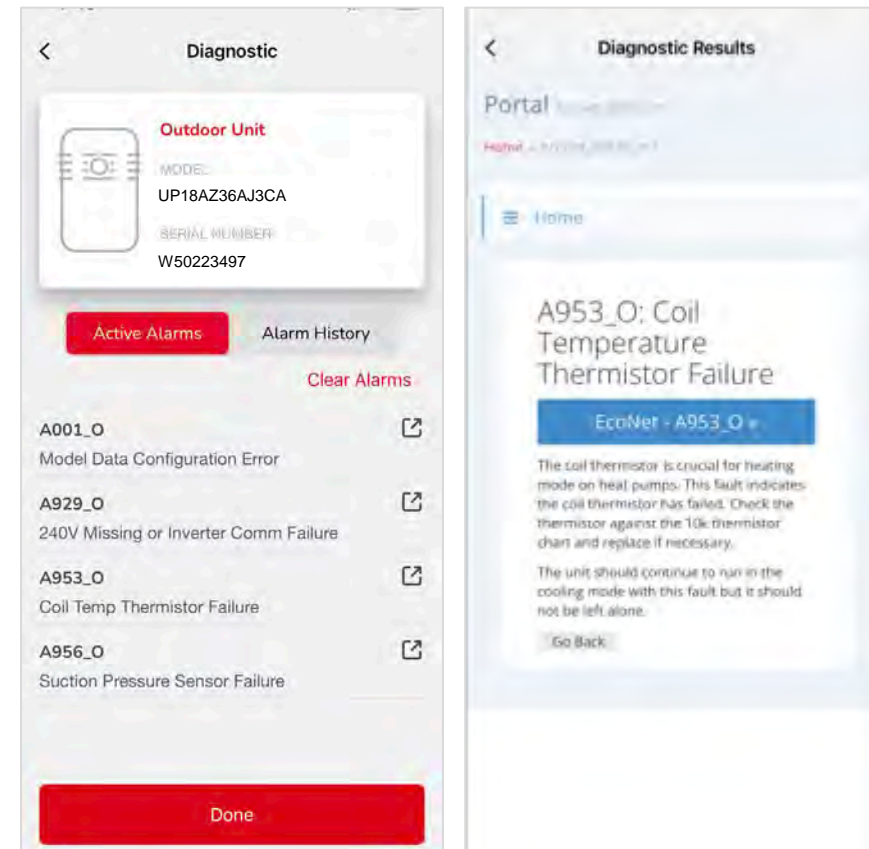

See Contractor App for EcoNet help pages *



TEST MODE

- Momentary press
 - Clears the lock timer to get the unit running under a normal cooling/heating request, given there is no Alarm.
 - The pressure differential still needs to be < 20 PSIG to start the unit.
- 3 second press (while unit is off)
 - “Bump” test
 - Turns the unit on for 1 minute in low cooling.
 - If liquid pressure > 500 or suction pressure < 50, turns off. If pressure differential > 100, goes to High Cooling. If pressure differential > 120 PSIG, turns off.
 - The drive may go to high speed directly under the usual conditions, outside temp > 95°F, saturated liquid temp > 120° F, high current draw (> 90%)
- 5 second press (while unit is in heat mode)
 - Forces defrost

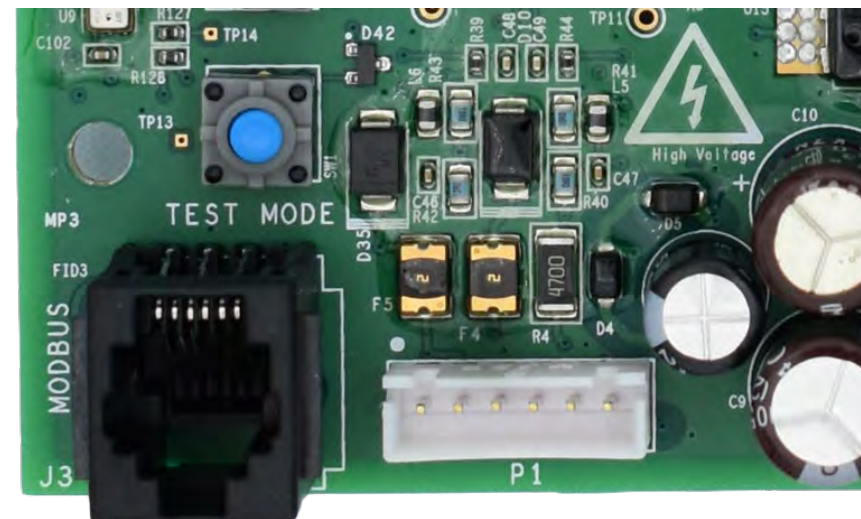



COMMUNICATION TROUBLESHOOTING

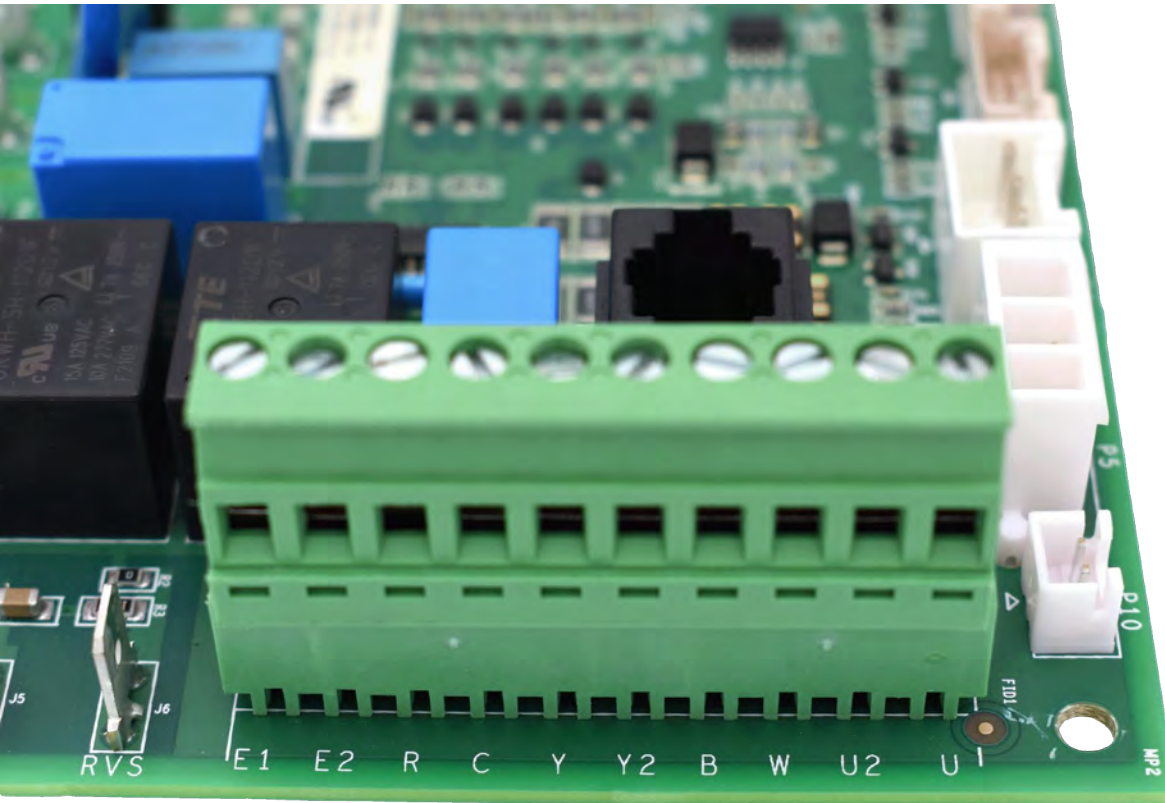

- EcoNet is an RS-485 serial bus, using two data wires (E1, E2) and a common (C). All devices have a green COM LED that should be blinking rapidly. Voltage readings:
- All devices disconnected, power applied to control:
 - E1 & E2 ~3 VDC
 - E1 & C ~3 VDC
 - E2 & C ~0 – 0.2 VDC
- Devices connected, power applied to control:
 - E1 & E2 ~1.0 – 3.5 VDC pulsating
 - E1 & C ~2.5 – 3.5 VDC pulsating
 - E2 & C ~0.1 – 1 VDC pulsating



LINE VOLTAGES/CURRENT

Line Operating Voltage

- Inverter Drive monitors voltage
- Operating voltage between L1 and L2 needs to be between 197VAC and 253VAC.
 - **Note:** In the event the voltage is greater than 253VAC, contact the local utility and have them reduce the voltage to the home.
- If line voltage > 265 VAC, unit will throw Overvoltage code
- If line voltage < 187 VAC, will throw Undervoltage code

L1/L2-
Line Voltage





COMPRESSOR OVER TEMPERATURE PROTECTION

Over temperature protection

- If discharge line temp (DLT) reaches 225°F more than 30 seconds:
 - Fault code displayed
 - Compressor RPM is reduced until DLT < 200°F
- Once DLT < 200°F compressor ramps to command speed

Discharge
Line Temp.





HIGH PRESSURE SWITCH

High Pressure Switch

- Connected directly to inverter
- Automatic reset
 - Opens: 610 PSI
 - Resets: 490 PSI
- Only considered during call for compressor operation

High Pressure Switch (HPC)

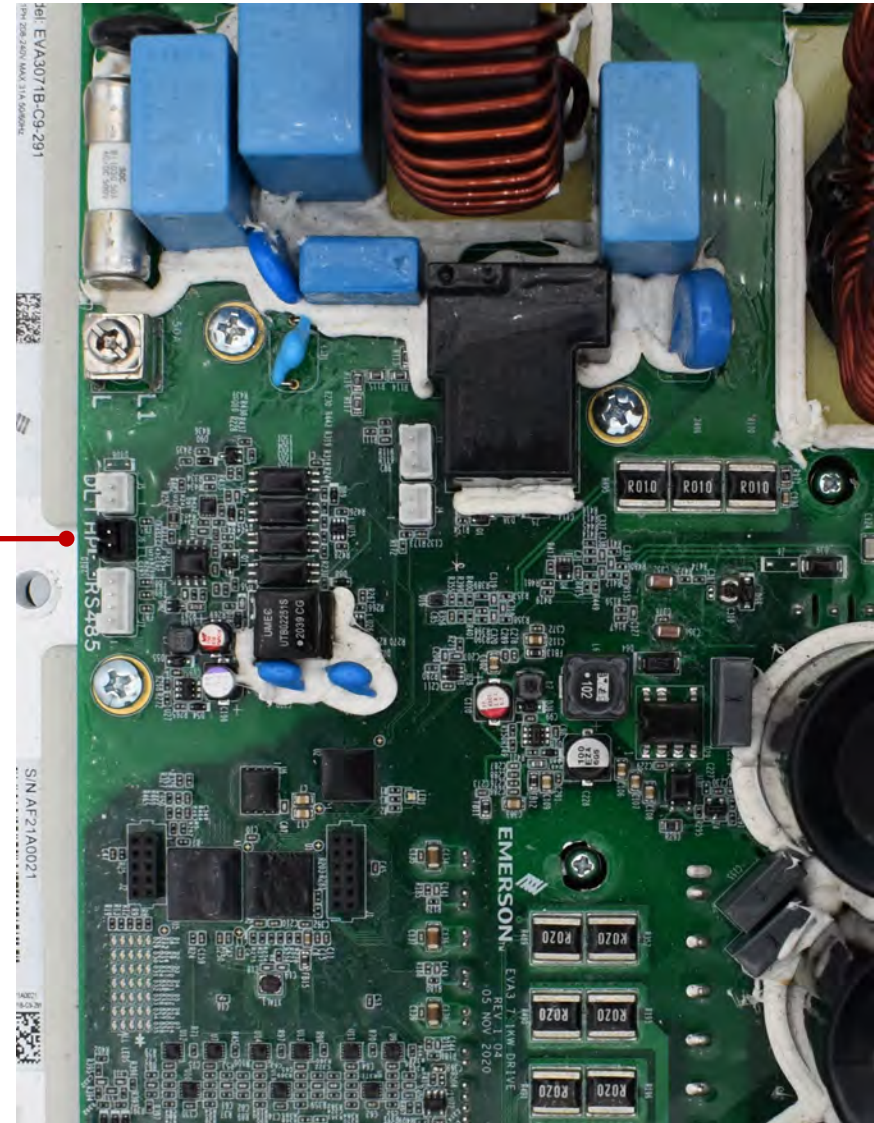



LOW PRESSURE SWITCH

Suction transducer permits different operating parameters:

- Cooling mode
 - Open: 50 psig
 - Close: 95 psig
- Heating mode
 - Open: 15 psig
 - Close: 40 psig

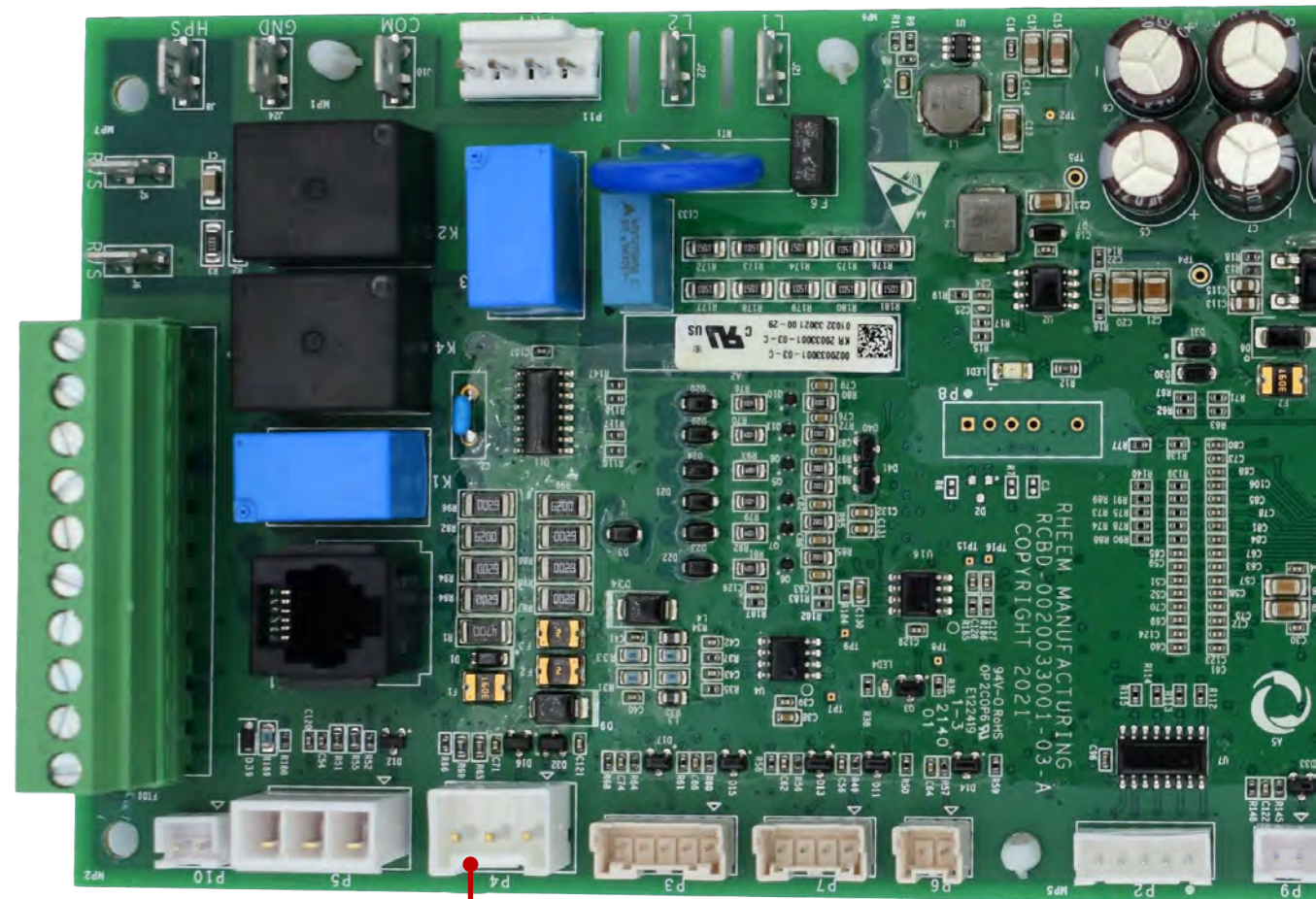

Low Pressure
(Suction Transducer)



RESOURCES & FOLLOW-UP



DOWNLOADING AND INSTALLING THE CONTRACTORS APP

You can download and install the Contractor App compatible with your operating system.

The App supports iOS 13 or later and Android 7 or later.

1 Do one of the following:

- On the unit, locate a blue label with a QR code and scan it with your smartphone. Select your brand. You are redirected to the app download page.

or

- In Google Play Store or the App Store on your smartphone, search **the name of the app**.

2 Download and install the Contractor App.



ATTENTION CONTRACTORS
APP REQUIRED FOR SYSTEM SETUP!

1. DOWNLOAD THE CONTRACTORS APP
Download App Here → 

2. CONNECT TO BLUETOOTH® TECHNOLOGY

FOR CONNECTION AND APP RELATED QUESTIONS, PLEASE CONTACT
CUSTOMER SUPPORT AT: (800) 255-2388



Apple and App Store are registered trademarks of Apple Inc.
Google Play is a service provided by Google LLC.

ctive owners.



- Installation Instructions
- Warranty

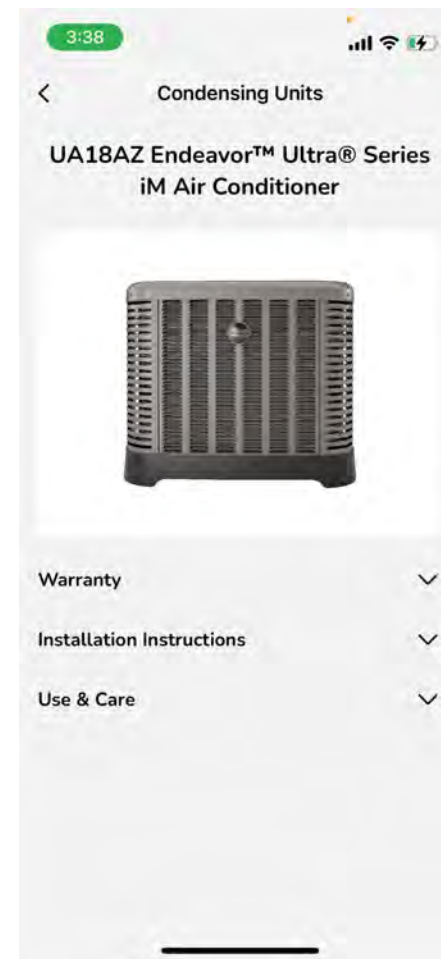
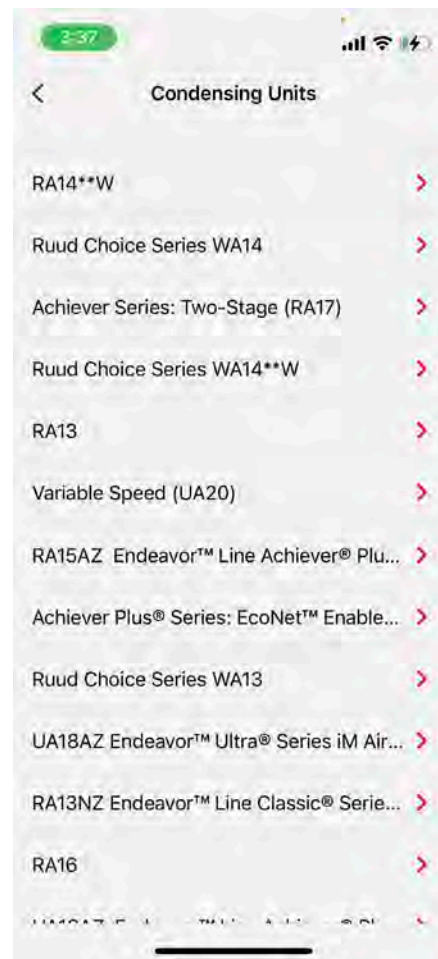
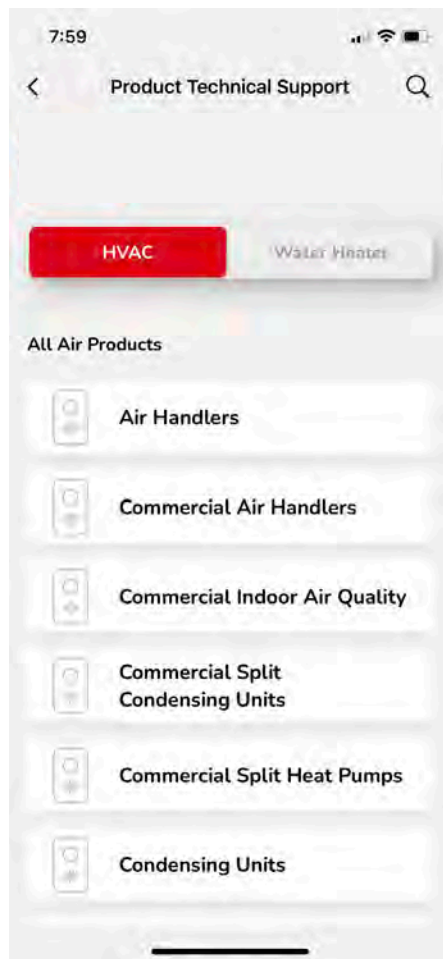



SHOW CUSTOMERS HOW YOU CAN HELP THEM LIVE MORE COMFORTABLY—AND RESPONSIBLY

Learn more about the Sustainability Standout™ seal and Ruud's commitment to sustainability: www.Ruud.com/Sustainability

Download a flyer to share with homeowners:



TM



KEY TAKEAWAYS

1 ECONET THERMOSTAT AND/OR CONTRACTOR APP IS REQUIRED

- Installation / Setup
- Diagnostic
- Service / Repair
- QR Code

2 BLUETOOTH TECHNOLOGY

- Internet connection not required for Bluetooth connection
- Antenna caution (handle gently)
- LED connectivity (blink or solid)

3 UODC BOARD (PREVIOUSLY VSODU)

- Same board is used on Mid-Tier & High-Tier systems
- No Memory card – Model Data is saved to UODC
- Installation/ Setup – EcoNet or Contractor App/Bluetooth
- Diagnostic – EcoNet or Contractor App/Bluetooth
- Service – EcoNet or Contractor App/Bluetooth
- Replacement boards – Contractor App/Bluetooth
- Mid-Tier Thermostat Wiring
- High-Tier Thermostat Wiring
- High-Tier and Mid-Tier BLDC fan motors wire directly to inverter drive
- High-Tier and Mid-Tier High Pressure Switch wires directly to inverter drive



THANK YOU!
QUESTIONS?